



BT fixo
www.btfixo.com.br

**LINHA
COMPLETA
DE PRODUTOS
2025**

ROSQUEADEIRA

ROSQUEADEIRA ELETRÔNICA COM BRAÇO ARTICULADO

Modelo: RE



Acessórios opcionais:



ROSQUEADEIRA CNC SEMI AUTOMÁTICA

Modelo: ZK-20



PLACAS PARA CENTRO

PLACA PNEUMÁTICA - PARA OPERAÇÕES EM MÁQUINAS COM MESA

Modelo: PPC

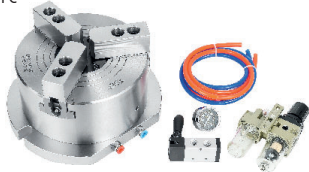

PLACA PARA CENTRO DE USINAGEM COM 3 CASTANHAS

Modelo: PSC



PLACA PARA CENTRO DE USINAGEM COM 4 CASTANHAS

Modelo: SSC

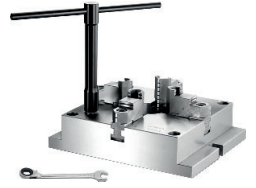

MAGNÉTICOS

BLOCO MAGNÉTICO

Modelo: ECMC



Item somente sob encomenda

BLOCO MAGNÉTICO

Modelo: SYT

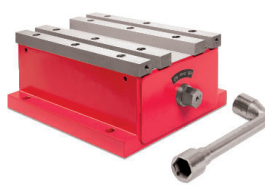

MESA MAGNÉTICA

Modelo: MMC



MESA MAGNÉTICA ELETROPERMANENTE

Modelo: PEMN



Acessórios Opcionais:

MESA DE SENO MAGNÉTICA PERMANENTE

Modelo: PMSM

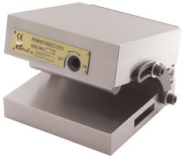

MESA MAGNÉTICA PERMANENTE

Modelo: PRM41



DIVISORES

DIVISOR UNIVERSAL

Modelo: BS-3



DIVISOR UNIVERSAL

Modelo: BS-2



DIVISOR SEMI UNIVERSAL

Modelo: BS-1

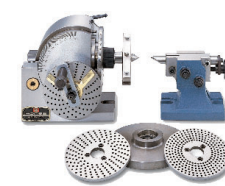

MESA DIVISORA VERTICAL/HORIZONTAL

Modelo: HHV

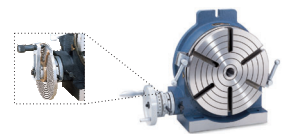

CONTRA PONTO

Modelo: TS



CONJUNTO CABEÇOTE ÂNGULO RETO

Modelo: NT-40



SUPER DIVISOR

Modelo: HSD



Item somente sob encomenda

CANTONEIRA DE FERRO FUNDIDO

Modelos: HL



MESA ANGULAR

Modelo: TT

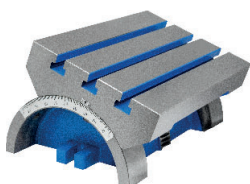

MESA COORDENADA

Modelo: CST

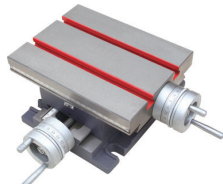

MORSAS



MORSA MECÂNICA ANGULAR
Modelo: HHY



MORSA HIDRÁULICA ANGULAR
Modelo: HW



MORSA ANGULAR UNIVERSAL
Modelo: HY



MORSA HIDRÁULICA
Modelo: HH



MORSA MECÂNICA
Modelo: H



MORSA DE PRECISÃO AUTO-CENTRANTE AJUSTÁVEL
Modelo: ASC

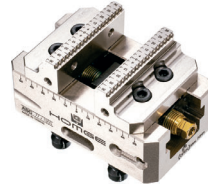

PINO PARA ZERO POINT
Modelos: M-52x52PS, M-96x96PS



SUPOORTE PARA ZERAMENTO DO ZERO POINT
Modelos: 8010, 8058



ZERO POINT - PARA UMA MORSA
Modelos: 8001, 8051



ZERO POINT - PARA DUAS MORSAS
Modelos: 7062, 8062, 8067



ZERO POINT - BASE ELEVATÓRIA
Modelos: 3131, 3133, 8222, 8226



MORSA AUTOCENTRANTE
Modelo: SC-1-4"



MORSA COMPACTA DUPLA DE PRECISÃO
Modelo: CD-4"



MORSA DE PRECISÃO
Modelo: QKG

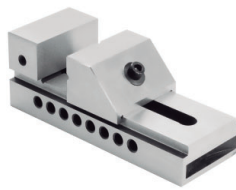

MORSA DE SENO
Modelos: VX



MORSA UNIVERSAL DE PRECISÃO
Modelo: CHM-80



MORSA DE PRECISÃO
Modelo: GTI



MORSA DE PRECISÃO CNC
Modelo: HVV

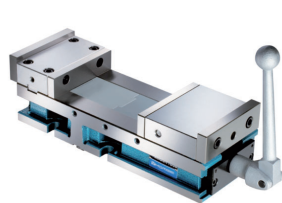

MORSA DE PRECISÃO CNC DE ÂNGULO ABERTO
Modelo: GH-6



MORSA DUPLA DE PRECISÃO CNC
Modelo: HDL-4"



MORSA PARA CNC MULTI-POWER DE ÂNGULO FIXO
Modelo: HPAC-130S



MORSA PARA CNC MULTI-POWER
Modelo: HPAQ-160



MORSA PARA CNC MULTI-POWER DE ÂNGULO FIXO
Modelo: HPAC-130



MORSA DE PRECISÃO PARA PRODUÇÃO
Modelo: HRV



MORSA DE PRECISÃO PARA PRODUÇÃO EM MÓDULO
Modelo: HRV-5013 (A,B,C,D,E)

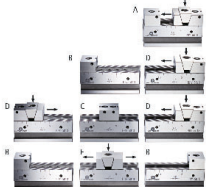

MINI MORSA

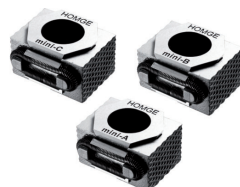

JOGO DE CALÇO PADRÃO



BORRACHA PARA MESA DE TRABALHO
Modelo: STZ

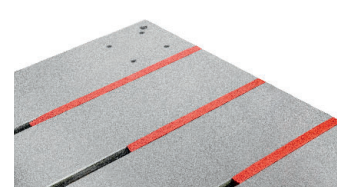

PATENTED
142711
M287204
M320459

PATENTED
142711
M287204
M320459
M338717

PATENTED
142711
M287204
M320459

PATENTED
126219

LINHA DE MANDRILHAMENTO

BTfixo

CONE MODULAR CBH
MODELO: BT

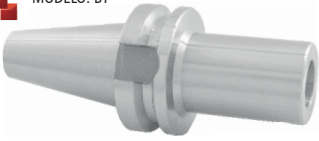

CONE MODULAR CBST
MODELO: BT

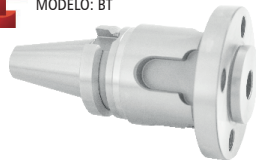

PROLONGADOR MODULAR CBH



CONE MODULAR CBH
MODELO: SK



CABEÇOTE ACABAMENTO CENTÉSIMAL



CABEÇOTE DESBASTE



KIT DE MANDRILHAMENTO
NBH2084 ø8 - ø280



CABEÇOTE BROQUEADOR



HASTES PARA CABEÇOTE BROQUEADOR



MANDRIS DUPLO CONTATO

PORTA PINÇA DBT - HQT



PORTA FRESA FACEAR DBT - HQT



PORTA PINÇA AUTO TORQUE DBT - HQT



MAS 403 BT

PORTA PINÇA (DMC)
(MAS 403 BT)



PORTA PINÇA AUTO TORQUE
(MAS 403 BT)



MANDRIL FLUTUANTE TROCA RÁPIDA
(MAS 403 BT)



PORTA PINÇA ER - SYNCHRO
(MAS 403 BT)



PORTA PINÇA ER (com Compensação Axial)
(MAS 403 BT)



CONE INDUÇÃO TÉRMICA SHRINK FIT
(MAS 403 BT)



PORTA PINÇA HIDRÁULICO
(MAS 403 BT)



PORTA BARRA WELDON COM REFRIGERAÇÃO LATERAL
(MAS 403 BT)

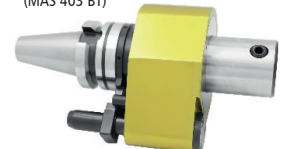

BUCHA PARA PORTA BARRA COM REFRIGERAÇÃO LATERAL



PORTA PINÇA COM REFRIGERAÇÃO LATERAL
(MAS 403 BT)



PORTA PINÇA ER - HQT
(MAS 403 BT)



PORTA PINÇA ER -
(MAS 403 BT)



CABEÇOTE ANGULAR 90°
(MAS 403 BT)



PORTA PINÇA SK
(MAS 403 BT)



PORTA BARRA WELDON
(MAS 403 BT)



PORTA BARRA WELDON - HQT
(MAS 403 BT)



CONE MODULAR
(MAS 403 BT)



PORTA FRESA COMBINADO
(MAS 403 BT) / (62358)



PORTA FRESA ROSCADO
(Porta Cápsula)
(MAS 403 BT)



PORTA FRESA FACEAR
(MAS 403 BT) / (DIN3937)



CONE REDUÇÃO
(MAS 403 BT)



PORTA CONE MORSE
(MAS 403 BT)



HASTE PARA MANDRIL
(MAS 403 BT)



MANDRIL APERTO RÁPIDO INTEGRADO
(MAS 403 BT)



MANDRIL APERTO RÁPIDO INTEGRADO - HQT
(MAS 403 BT)



CONE PARA TESTE DE PRECISÃO DO SPINDLE
(MAS 403 BT)



BT fixo

DIN 69871-SK

PORTA PINÇA (DMC)
(DIN 69871)



PORTA PINÇA AUTO TORQUE
(DIN 69871)



MANDRIL FLUTUANTE TROCA RÁPIDA
(DIN 69871)

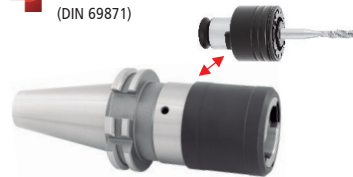

PORTA PINÇA HIDRÁULICO
(DIN 69871)



CONE INDUÇÃO TÉRMICA - SHRINK FIT



PORTA PINÇA ER - HQT
(DIN 69871)



PORTA PINÇA ER
(DIN 69871)

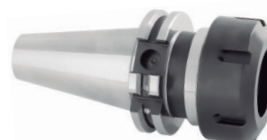

PORTA BARRA WELDON
(DIN 69871)



PORTA PINÇA SK
(DIN 69871)



CONE MODULAR
(DIN 69871)



PORTA FRESA COMBINADO
(DIN 69871) / (62358)



PORTA FRESA ROSCADO
(Porta Cápsula)
(DIN 69871)



PORTA FRESA FACEAR
(DIN 69871)



PORTA CONE MORSE
(DIN 69871)



HASTE PARA MANDRIL
(DIN 69871)



MANDRIL APERTO RÁPIDO INTEGRADO
(DIN 69871)



DIN 69893-HSK (FORMA A)

PORTA PINÇA (DMC)
(DIN 69893)



PORTA PINÇA AUTO TORQUE
(DIN 69893)



CONE INDUÇÃO TÉRMICA SHRINK FIT
(DIN 69893)



PORTA PINÇA HIDRÁULICO
(DIN 69893)



PORTA PINÇA SK
(DIN 69893)



CONE PARA TESTE DE PRECISÃO DO SPINDLE
(DIN 69893)



PORTA PINÇA ER
(DIN 69893)



PORTA BARRA WELDON
(DIN 69893)



PORTA FRESA ROSCADO
(DIN 69893)



PORTA FRESA FACEAR
(DIN 69893) / (DIN 3937)



DIN 69893-HSK (Forma E)

PORTA PINÇA (DMC)
(DIN 69893) / (Forma E)



PORTA PINÇA HIDRÁULICO
(DIN 69893) / (Forma E)



PORTA PINÇA SK
(DIN 69893) / (Forma E)



PORTA PINÇA ER
(DIN 69893) / (Forma E)



DIN ISO20 / DIN ISO30

PORTA PINÇA
ISO20



PORTA PINÇA ER
ISO30



PORTA PINÇA ER
(DIN 69893) / (Forma F)



DIN 2080 ISO

PORTA PINÇA
(DIN 2080)



PORTA BARRA WELDON
(DIN 2080)



PORTA FRESA COMBINADO
(DIN 2080) / (DIN 6358)



PORTA FRESA FACEAR
(DIN 2080) / (DIN 3937)



PORTA CONE MORSE
(DIN 2080)



HASTE PARA MANDRIL
(DIN 2080)



CONE MORSE DIN 228

PORTA PINÇA ER
(DIN 228 A)



PORTA PINÇA ER
(DIN 228 B)



PORTA FRESA FACEAR
(DIN 228 A) / (3937)



HASTE CÔNICA
(DIN 228 B)



BUCHA DE REDUÇÃO
(DIN 228 B)



BUCHA PROLONGADORA
(DIN 2187)



MANDRIL FLUTUANTE TROCA RÁPIDA
(DIN 228 B)



CABEÇOTE ROSQUEADOR
(DIN 228 B)



HASTE PARALELA

PORTA PINÇA (HASTE PARALELA) - (DMC)



PORTA PINÇA (HASTE PARALELA)



PORTA PINÇA (HASTE PARALELA) SYNCHRO



MANDRIL FLUTUANTE TROCA RÁPIDA (HASTE PARALELA)

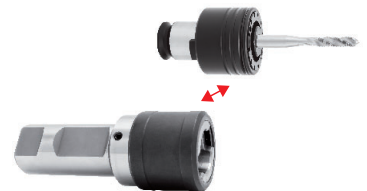

PORTA ALARGADOR FLUTUANTE



PORTA PINÇA (HASTE PARALELA) Com Compensação Axial



MANDRIL RÍGIDO TROCA RÁPIDA (CONE INTERNO)



HASTE PARALELA PARA MANDRIL



LINHA MODULAR

CONE MODULAR
(MAS 403 BT)



CONE MODULAR
(DIN 69871)



PROLONGADOR PARA CONE MODULAR



PROLONGADOR PORTA FRESA FACEAR PARA CONE MODULAR



PROLONGADOR PORTA BARRA WELDON - PARA CONE MODULAR



PROLONGADOR PORTA PINÇA ER PARA CONE MODULAR



PINÇAS



PINÇA ER
(DIN 6499)



JOGO DE PINÇAS ER COM CONE E CHAVE
Modelos: BT, CM, ISO



ANEL DE VEDAÇÃO PARA PINÇA



JOGO DE PINÇAS ER (CAIXA DE PLÁSTICO)
Modelo: ER



PORCA PARA ANÉIS DE VEDAÇÃO



PINÇA SELADA (VEDADA)
ER (DIN 6499)



JOGO DE PINÇAS VEDADA ER
Modelos: ER



PINÇA PORTA MACHO COM COMPENSAÇÃO AXIAL
(DIN 6499)



PINÇA PORTA MACHO



PINÇA (DMC)



PINÇA SK



PINÇA OZ
(DIN 6388A)



JOGO DE PINÇAS OZ
Modelo: OZ



JOGO DE PINÇAS OZ COM CONE E CHAVE
Modelo: ISO-40



JOGO DE PINÇAS HIDRÁULICAS COM CONE (MAS 403 BT)



PINÇA PARA CONE HIDRÁULICO (VEDADA)
(REDUÇÃO)



PINÇA PARA CONE AUTO TORQUE
(REDUÇÃO)



PINÇA PARA AFIADORA
Modelo: RU2



ACESSÓRIOS

BTfixo

ADAPTADOR PARA TROCA RÁPIDA - Com Embreagem de Segurança



ADAPTADOR PARA TROCA RÁPIDA - Sem Embreagem de Segurança



ADAPTADOR PARA TROCA RÁPIDA - Sem Embreagem de Segurança (Porta Pinça)



REDUÇÃO PARA ADAPTADOR



DISPOSITIVO DE APERTO CALIBRADOR PARA PINOS E PORCAS
Modelo: HT07



PONTEIRA COM ENCAIXE TIPO E (4 PONTAS) PARA DISPOSITIVO DE APERTO
Modelo: TWR05



PONTEIRA COM ENCAIXE TIPO UNHA PARA DISPOSITIVO DE APERTO
Modelo: TWR06



PONTEIRA COM ENCAIXE SEXTAVADO PARA DISPOSITIVO DE APERTO
Modelo: TWR07



DISPOSITIVO DE APERTO CALIBRADOR
Modelo: MTD6-NS



PONTEIRA TORX COM ENCAIXE 1/4" SEXTAVADO



TUBO DE REFRIGERAÇÃO PARA CONE HSK



CHAVE PARA TUBO DE REFRIGERAÇÃO



PINO DE FIXAÇÃO



PINO ADAPTADOR BT PARA ISO (DIN2080)



PINÇA PARA PINO - ROSCA INTERNA E EXTERNA BT MAS 403 BT (DIN 6499)



PORCA PARA PINÇA



CHAVE PARA PORCA



Modelo: M



Modelo: OZ



Modelo: T1



Modelo: T2- 4 pontas



Modelo: T2 UNHA

MANDRIL

CHAVE PARA MANDRIL



CHAVE PARA MANDRIL APERTO RÁPIDO SUPER



MANDRIL COM CHAVE LINHA LEVE



MANDRIL COM CHAVE LINHA PESADA



MANDRIL COM CHAVE LINHA PESADA EXTRA



MANDRIL DE APERTO RÁPIDO



MANDRIL DE APERTO RÁPIDO SUPER



FLEXÍVEL PLÁSTICO - JOGO
Modelo: HZ



FLEXÍVEL PLÁSTICO

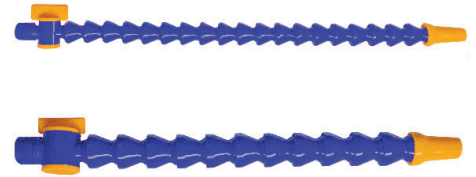

BLOCO EM V - MAGNÉTICO



BASE MAGNÉTICA ARTICULADA COM AJUSTE FINO



LUMINÁRIA LED



SUPORTE PARA TROCA DE FERRAMENTAS
Modelos: LD, HSK



SUPORTE PARA TRANSPORTE DE FERRAMENTAS E SUPORTE DE BANCADA
Modelos: TC, RPC



PRESETER COM RELÓGIO



PRESETER ELETRÔNICO



PRESETER DIGITAL



RELÓGIO APALPADOR



LOCALIZADOR DE ARESTAS
Modelo: CB



SENSOR DE LOCALIZAÇÃO COM BIP E LED



LEVANTADOR MAGNÉTICO
Modelo: LS1



TORNO DE BANCADA



PINÇAS MAGNÉTICAS DE SEGURANÇA SIMPLES
Modelo: SP



PINÇAS MAGNÉTICAS DE SEGURANÇA DUPLA
Modelo: TP



MÁQUINA DE INDUÇÃO TÉRMICA
Modelo: GTS-306



Item somente sob encomenda

MÁQUINA DE INDUÇÃO TÉRMICA
Modelo: GTS-9000



Item somente sob encomenda

PLACAS

BTfixo

PLACA 3 CASTANHAS - COMBINADA (AUTO. E INDEP)

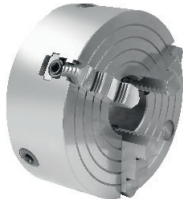

PLACA 4 CASTANHAS - COMBINADA (AUTO. E INDEP)



PLACA AUTOCENTRANTE COM 3 CASTANHAS MONOBLOCO FIXAÇÃO TRASEIRA

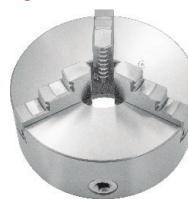

PLACA AUTOCENTRANTE COM 3 CASTANHAS MONOBLOCO FIXAÇÃO FRONTAL

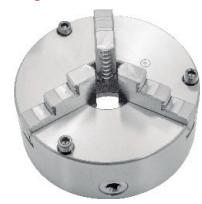

PLACA AUTOCENTRANTE COM 3 CASTANHAS MONOBLOCO CORPO DE AÇO



PLACA AUTOCENTRANTE COM 3 CASTANHAS REVERSÍVEIS FIXAÇÃO TRASEIRA

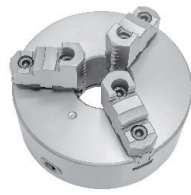

PLACA AUTOCENTRANTE COM 3 CASTANHAS REVERSÍVEIS FIXAÇÃO FRONTAL

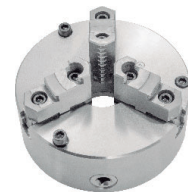

PLACA AUTOCENTRANTE COM 3 CASTANHAS REVERSÍVEIS FIXAÇÃO FRONTAL CORPO DE AÇO



PLACA AUTOCENTRANTE COM 3 CASTANHAS MONOBLOCO FIXAÇÃO CAMLOCK

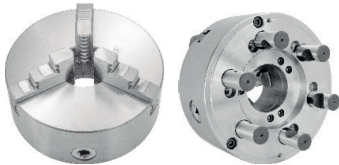

PLACA AUTOCENTRANTE COM 3 CASTANHAS REVERSÍVEIS FIXAÇÃO CAMLOCK

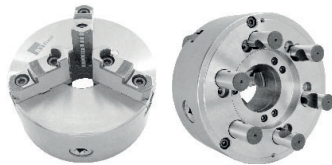

PLACA AUTOCENTRANTE COM 3 CASTANHAS MONOBLOCO COM HASTE CÔNICA



PLACA AUTOCENTRANTE COM 4 CASTANHAS MONOBLOCO FIXAÇÃO TRASEIRA



PLACA AUTOCENTRANTE COM 4 CASTANHAS REVERSÍVEIS FIXAÇÃO TRASEIRA



PLACA INDEPENDENTE COM 4 CASTANHAS MONOBLOCO

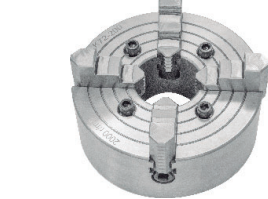

PLACA AUTOCENTRANTE COM 6 CASTANHAS MONOBLOCO FIXAÇÃO TRASEIRA

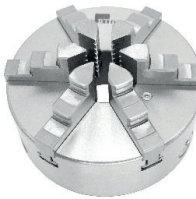

PLACA HIDRÁULICA



PLACA HIDRÁULICA DE PRECISÃO (0,003)



FLANGE CONE CURTO PARA PLACAS UNIVERSAIS E INDEPENDENTES

ASA B-5.9-1960
CAMLOCK

ASA B-5.9-1954
TIPO L

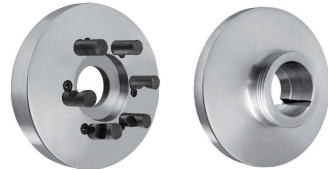

PEÇAS DE REPOSIÇÃO

ANEL ESPIRAL



PINHÃO



CHAVE PARA PLACA



CASTANHAS MONOBLOCO EXTERNA

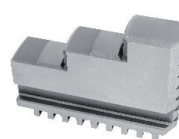

CASTANHAS MONOBLOCO INTERNA

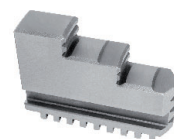

CASTANHAS BASE

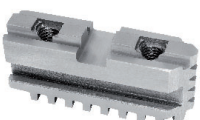

CASTANHAS SOBREPOSTAS

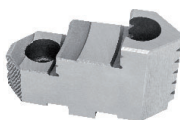

GUIA PARA CASTANHA

Modelo: AUTOBLOCK



GUIA PARA CASTANHA

Modelo: KITAGAWA

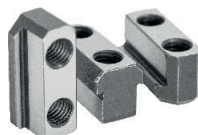

CASTANHA MOLE

Modelos: KITAGAWA, AUTOBLOCK

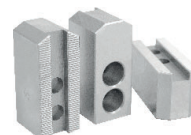

CASTANHA DURA

Modelos: KITAGAWA, AUTOBLOCK



PONTOS

<p>PONTO ROTATIVO</p>	<p>PONTO ROTATIVO CARGA LEVE</p>	<p>PONTO ROTATIVO PRECISÃO</p>	<p>Modelo A</p> <p>Modelo B</p>			
<p>PONTO ROTATIVO COMPACT</p> <p>Modelo A</p> <p>Modelo B</p> <p>Modelo I</p>	<p>PONTO ROTATIVO HIGH PERFORMANCE</p> <p>Modelo A</p> <p>Modelo B</p>					
<p>PONTO ROTATIVO HIGH SPEED</p> <p>Modelo A</p> <p>Modelo B</p> <p>Modelo I</p>	<p>PONTO ROTATIVO SUPER HIGH SPEED</p> <p>Modelo A</p> <p>Modelo B</p>					
<p>PONTO ROTATIVO SUPER CARGA</p>	<p>PONTO ROTATIVO PARA TUBO (Orbital)</p>	<p>PONTO DE ARRASTE</p>				
<p>PONTO FIXO DE ARRASTE</p>	<p>BUCHA PARA PONTO DE ARRASTE</p>					
<p>PONTO DE ARRASTE FRONTAL</p>	<p>PONTO FIXO HSS PONTA ESTENDIDA COM PORCA EXTRATORA</p>	<p>PONTO FIXO HSS COM PORCA EXTRATORA</p>				
<p>PONTEIRAS DE REPOSIÇÃO PARA PONTOS ROTATIVOS COM PONTAS INTERCAMBIÁVEIS</p>						
<p>H230</p>	<p>H212</p>	<p>H210</p>	<p>H208</p>	<p>H206</p>	<p>H205</p>	<p>H200</p>
<p>PONTO FIXO COM INSERTO DE METAL DURO</p>	<p>PONTO FIXO HSS</p>					

VDI

<p>BUCHA REDUÇÃO PARA VDI</p>	<p>BUCHA EXCÊNTRICA PARA AJUSTE DO CENTRO DA BROCA</p>	<p>FERRAMENTA ACIONADA BMT - AXIAL (DIN 1809)</p>	<p>FERRAMENTA ACIONADA BMT - RADIAL (DIN 1809)</p>
<p>FERRAMENTA ACIONADA VDI - AXIAL (DIN 1809)</p>	<p>FERRAMENTA ACIONADA VDI - RADIAL (DIN 1809)</p>	<p>FERRAMENTA ACIONADA VDI - AXIAL (DIN 5480)</p>	<p>FERRAMENTA ACIONADA VDI - RADIAL (DIN 5480)</p>

FERRAMENTA ACIONADA VDI - AXIAL (DIN 5482)

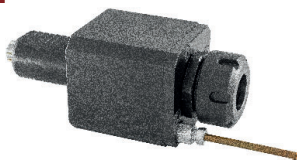

FERRAMENTA ACIONADA VDI - RADIAL (DIN 5482)



BMT - FRONTAL



BMT - LATERAL



BMT - LATERAL INVERTIDO



BMT - LATERAL DUPLO



BMT - LATERAL DUPLO INVERTIDO



BMT - PORTA FERRAMENTA



SUPORE CASTELO - PORTA FERRAMENTAS



SUPORE CASTELO - FRONTAL



VDI LATERAL (RADIAL) DIREITO (DIN 69880 B1)



VDI LATERAL (RADIAL) ESQUERDO (DIN 69880 B2)



VDI LATERAL (RADIAL) DIREITO INV. (DIN 69880 B3)



VDI LATERAL (RADIAL) ESQUERDO INV. (DIN 69880 B4)



VDI FRONTAL (AXIAL) DIREITO (DIN 69880 C1)



VDI FRONTAL (AXIAL) ESQUERDO (DIN 69880 C2)



VDI PORTA BARRA WELDON (DIN 69880 E2)



VDI PORTA PINÇA ER (DIN 6499) (DIN 69880 E4)



VDI FRONTAL (AXIAL) DIREITO INV. (DIN 69880 C3)



VDI FRONTAL (AXIAL) ESQUERDO INV. (DIN 69880 C4)



ACESSÓRIOS PARA FIXAÇÃO

GRAMPO BAR PULLER

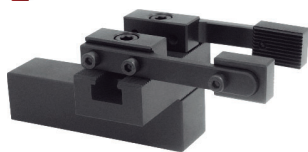

JOGO DE PRESILHAS PARA FIXAÇÃO

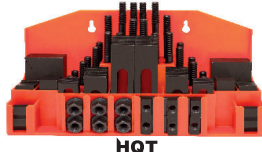

HQT



ACC

PARAFUSOS CABEÇA "T" (PCT-0009)



PORCA SEXTAVADA (PS-0006)

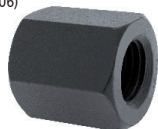

PORCA COM COLAR (PC-0008)



PORCA "T" (PT-0005)

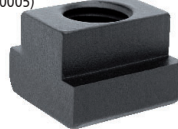

TIRANTE ROSCADO (TR-0004)



ARRUELA LISA (AL-0007)

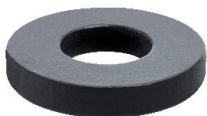

CALÇO REGULÁVEL (CR-0017)



GRAMPO FECHADO COM PARAFUSO DE ENCOSTO

GF-M12/110 GF-M14/130 GF-M16/150 GF-M20/200



GRAMPO PARA FIXAÇÃO LATERAL

GFL-M12 GFL-M14 GFL-M16



MORSA DE FIXAÇÃO LIVRE Modelo: FV



MANDRIL AUTO TORQUE - HIGH PRECISION



MANDRIL BÁSICO



EXTENSORES E REDUTORES

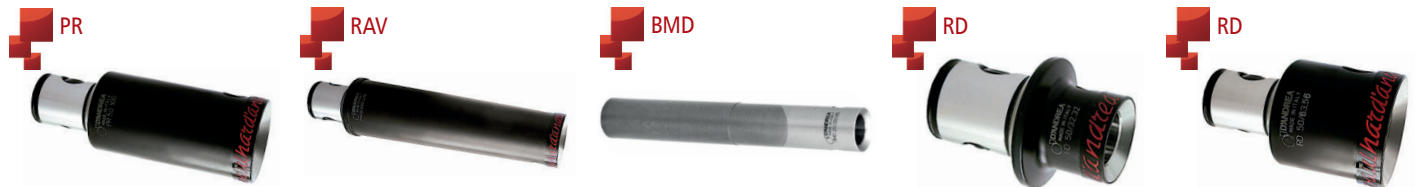

MANDRILHAMENTO

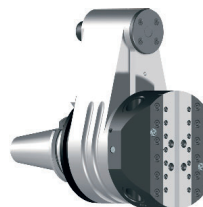

CABEÇOTE ANGULAR

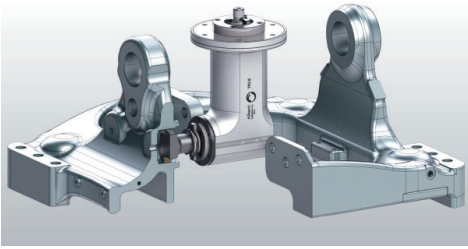

CABEÇOTE 90° COM OU SEM FLANGE
PARA GRANDES PEÇAS

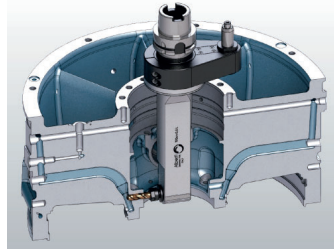

CABEÇOTE 90° LONGO

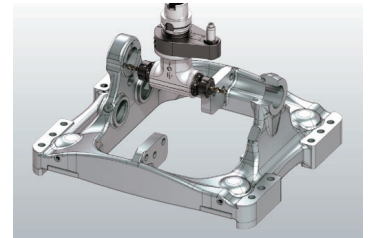

CABEÇOTE FIXO COM MANDRIS
OPOSTOS

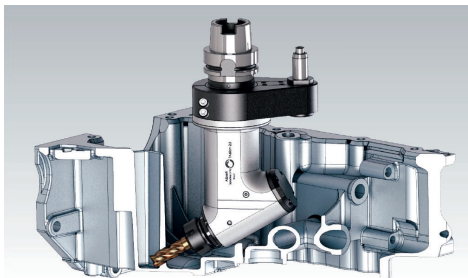

CABEÇOTE FIXO COM ÂNGULO VARIÁVEL

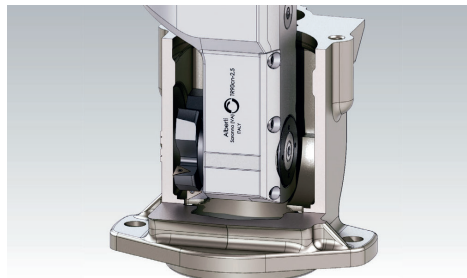

CABEÇOTE PARA ESPAÇOS RESTRITOS

LINEA CONTROL

T90cn-1,5

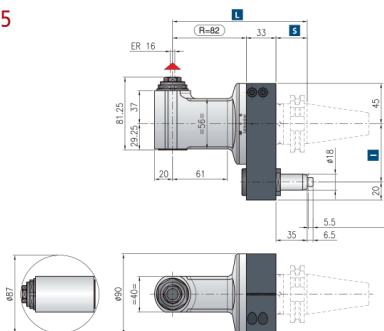

T90cn-2,5

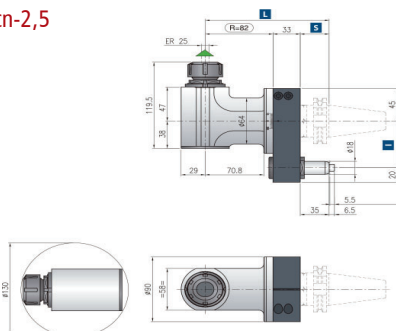

T90cn-3,5

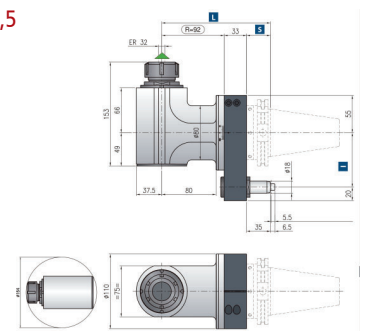

T90cn-5

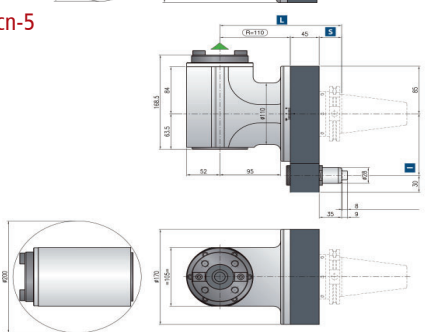

TCUcn-1,5

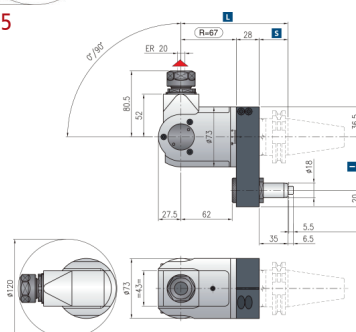

TCUcn-2,5

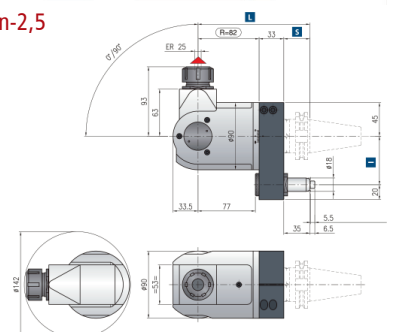

LINEA ALUMINUM

T90cn-3,5M

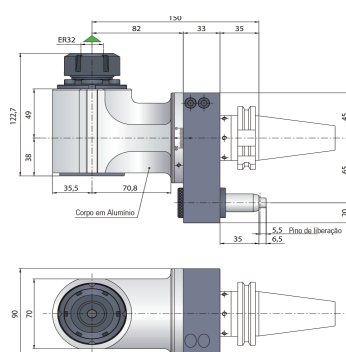



R. Jacobe Cemin, 68 - Nossa Sra. de Fátima,
Caxias do Sul - RS, 95041-230
Fone: (54) 3021-4119
E-mail: vendas@btfixo.com.br
www.btfixo.com.br