



---

**LANÇAMENTOS 2024**

---



# ROSQUEADEIRA ELETRÔNICA COM BRAÇO ARTICULADO - COM NR-12

Modelo: RE

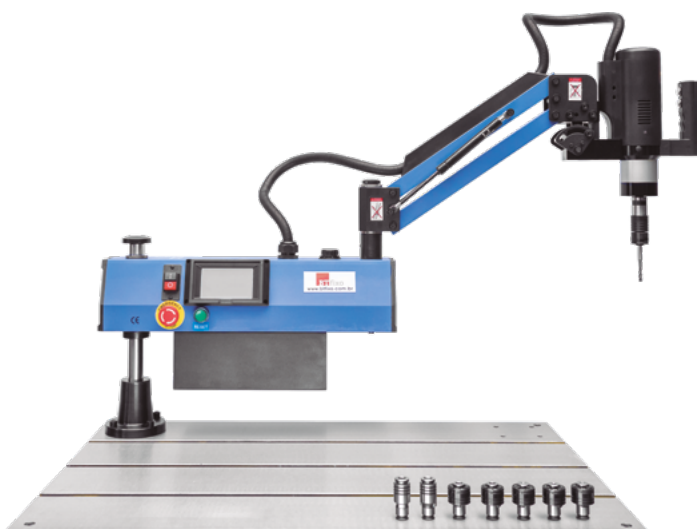

- Posição de rosqueamento (4x90°).
- Painel digital para ajustes de funções:
- Seleção de roscas e função "pica-pau"
- Controle de velocidade
- Controle de torque
- Controle de profundidade
- Motor elétrico: 220V / 60Hz-1Ph

## Acessório Opcional:



Dimensões: 600x900x700mm.  
5 Gavetas e 1 porta.  
Mesa com rasgo "T" M12.



Para maiores informações  
escaneie o QR code acima

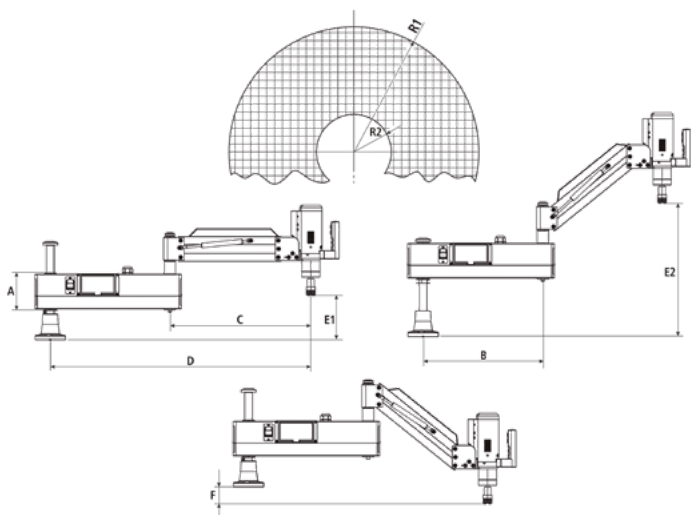

Modelo	R1	R2	A	B	C	D	E1	E2	F
M3 - M16	1010	330	145	465	545	1010	170	488	75
M6 - M24	1095	370	145	465	630	1095	140	530	175
M6 - M36	1140	405	145	510	630	1140	110	530	175

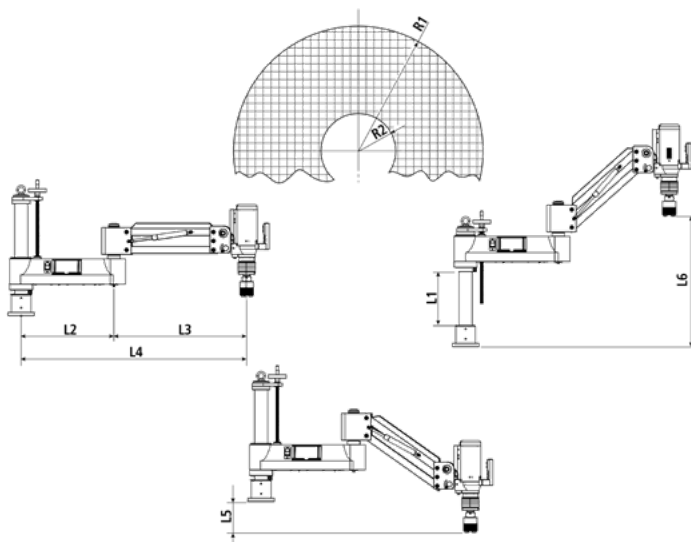

Modelo	R1	R2	L1	L2	L3	L4	L5	L6
M12 - M48	1260	405	299	518	742	1260	222	673



# ROSQUEADEIRA ELETRÔNICA COM BRAÇO ARTICULADO - COM NR-12

Modelo: RE



OUTUBRO 2024

Código	Lubrificação	NR-12	Capacidade	Rotação	Faixa Trabalho	Adaptadores com embreagem de segurança			Potência	Peso Total (kg)	
						Modelo	Ø	∠			Rosca
06339	Não	Sim	M3 - M16	0 - 312 RPM	Horizontal 1000mm Vertical 400mm	KWES / 1B	3,50	2,70	M3 - M5 - 1/8"	600w	30
							4,50	3,40	M4 - M6 - 5/32" - 1/4"		
							6,00	4,90	M5 / M6		
							8,00	6,20	M8 - 5/16"		
							10,00	8,00	M10		
							9,00	7,00	M12 - 3/8" - 1/2"		
05855	Sim	Sim	M3 - M16	0 - 312 RPM	Horizontal 1000mm Vertical 400mm	KWES / 1 *	11,00	9,00	M14 - G1/4" *	600w	30
							12,00	9,00	M16 - G3/8" - 5/8" *		
							6,00	4,90	M5 / M6		
05746	Sim	Sim	M6 - 24	0 - 200 RPM	Horizontal 1200mm Vertical 400mm	KWES / 2B	8,00	6,20	M8 - 5/16"	1200w	46
							10,00	8,00	M10		
							9,00	7,00	M12 - 3/8" - 1/2"		
							11,00	9,00	M14 - G1/4"		
							12,00	9,00	M16 - G3/8" - 5/8"		
							14,00	11,00	M18 - 3/4"		
							16,00	12,00	M20 - G1/2"		
							18,00	14,50	M22 / M24 - G5/8" - 7/8"		
							6,00	4,90	M5 / M6		
05832	Sim	Sim	M6 - 36	0 - 125 RPM	Horizontal 1200mm Vertical 400mm	KWES / 2B	8,00	6,20	M8 - 5/16"	1200w	56
							10,00	8,00	M10		
							9,00	7,00	M12 - 3/8" - 1/2"		
							11,00	9,00	M14 - G1/4"		
							12,00	9,00	M16 - G3/8" - 5/8"		
							14,00	11,00	M18 - 3/4"		
							16,00	12,00	M20 - G1/2"		
							18,00	14,50	M22 / M24 - G5/8" - 7/8"		
						Redutor	KWRE 3/2				
						KWES / 3 *	20,00	16,00	M27 - G3/4" - 1" *		
							22,00	18,00	M30 - G7/8" - 1.1/8" *		
25,00	20,00	M33 - G1" - 1.1/4" *									
28,00	22,00	M36 - G1.1/8" - 1.3/8" *									
06340	Sim	Sim	M12-48	0-50 RPM E 0-250 RPM	Horizontal 1200mm Vertical 400mm	KWES / 2B	9,00	7,00	M12 - 3/8" - 1/2"	1200w	137
							11,00	9,00	M14 - G1/4"		
							12,00	9,00	M16 - G3/8" - 5/8"		
							14,00	11,00	M18 - 3/4"		
							16,00	12,00	M20 - G1/2"		
							18,00	14,5	M22 / M24 - G5/8" - 7/8"		
						Redutor	KWRE 3/2				
						KWES / 3B *	20,00	16,00	M27 - G3/4" - 1" *		
							22,00	18,00	M30 - G7/8" - 1.1/8" *		
							25,00	20,00	M33 - G1" - 1.1/4" *		
							28,00	22,00	M36 - G1.1/8" - 1.3/8" *		
							32,00	24,00	M39/M42 - 1.1/2" - 1.5/8" *		
							36,00	29,00	M45/M48 - G1.3/8 - 1.3/4 - G1.1/2 - 1.7/8" *		

\*Sem embreagem de segurança.

# ROSQUEADEIRA CNC SEMI AUTOMÁTICA

Modelo: ZK-20

A Rosqueadeira CNC Automática, modelo ZK-20, foi desenvolvida para aplicações de rosqueamento automático, onde há necessidade de produção.



Diâmetro da coluna: 70mm

Voltagem: 220v/50hz

Curso do eixo: 100mm

Distância entre a extremidade do eixo até a mesa: 400mm

Cone do eixo: B18 e mandril troca rápida Tam: 1

Dimensões da base: 528mm x 360mm

Acompanha controle de acionamento

Acompanha pedal de acionamento

Código	Lubrificação	NR-12	Capacidade	Rotação	Potência	Peso Total (kg)
06126	Não	Sim	M3 - M12	10 - 300 RPM	750w	120

Adaptadores com embreagem de segurança			
Modelo	∅	∠	Rosca
M Tam:1	3,50	2,70	M3 - M5 - 1/8"
	4,50	3,40	M4 - M6 - 5/32" - 1/4"
	6,00	4,90	M5 / M6
	8,00	6,20	M8 - 5/16"
	10,00	8,00	M10
	9,00	7,00	M12 - 3/8" - 1/2"

# PINÇA PARA AFIADORA

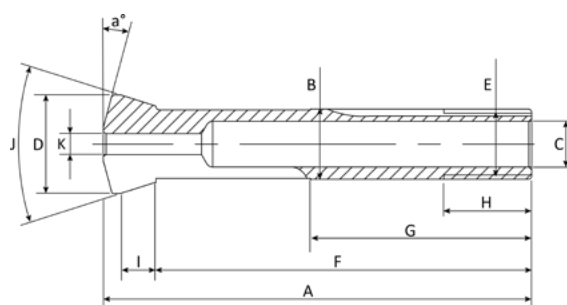

Modelo	A	a°	B	C	D	E	F	G	H	I	J
RU2	122	15°	20	1, 2, 3, 4, 5, 6, 7, 8, 9, 10, 11, 12, 13, 14, 15, 16	28	S20X2	107	63	25	10	35°12'

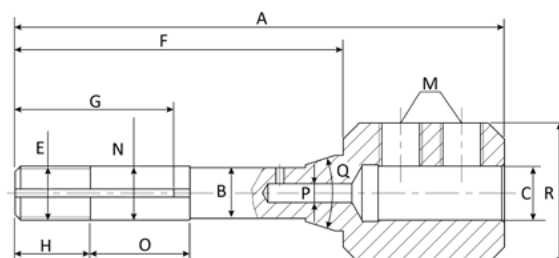

Modelo	A	B	C	E	F	G	H	N	O	P	Q	R
RU2	128	19	17, 18, 19, 20, 21, 22, 23, 24, 25, 26, 28	S20X2	122	56	28	20	37	8	35°12'	52



## DIVISOR UNIVERSAL

Modelo: BS-3 (160)

O divisor universal BS-3 (160) é um dos acessórios mais importantes para fresadoras.

Com o auxílio desta ferramenta, a peça de trabalho, presa entre os centros ou em um mandril, pode ser girada em qualquer ângulo conforme desejado e dividida em partes iguais. Com a utilização de ferramentas de corte adequadas, o divisor também pode ajudar a fresadora a realizar a operação de fresamento de canal, engrenagem de dentes retos, canal espiral, came de Arquimedes, canal helicoidal entre outros.

Este modelo foi projetado para consumidores com necessidades especiais, com eixo aprimorado para melhor performance.

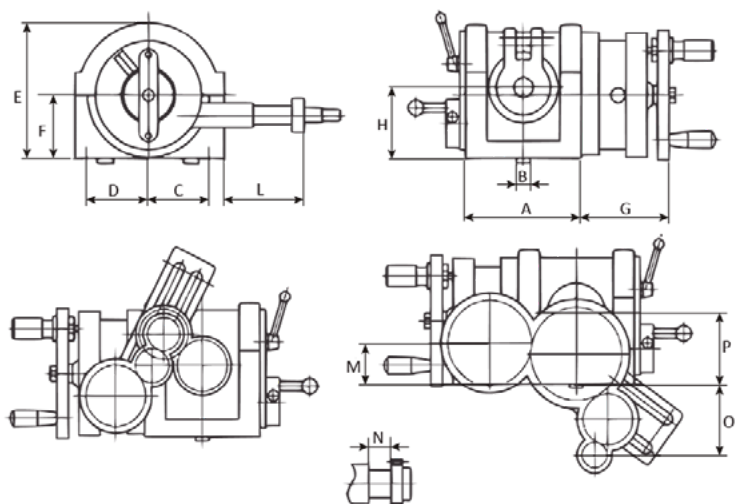
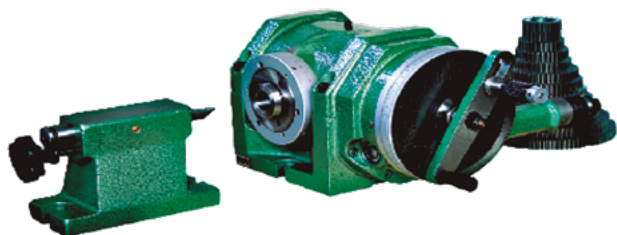

Código	Modelo	A	B	C	D	E	F	G	H	L	M	N	O	P	Peso (Kg)
06646	B5-3 (160)	209	18	116	98	259	152	120	160	103	68.5	34.5	100	160	120 (130)

### Acessórios:

Disco Divisor A e B.

Número de Furos no Disco

(relação e redução da engrenagem 40:1)

Nº de furos	Disco A	24	25	28	30	34	37	38	39	41	42	43
	Disco B	46	47	49	51	53	54	58	59	62	66	-

Altura Central	Ângulo de rotação do fuso a partir da posição horizontal (para cima)	Posição horizontal (para baixo)	Ângulo necessário para uma volta completa do divisor	Min. leitura de nônio	Imprecisão no alinhamento do eixo após uma rotação completa do divisor.	Imprecisão em 1/4 de volta do fuso
160	$\leq 95^\circ$	$\leq 5^\circ$	$9^\circ$	10"	$\pm 45''$	$\pm 1'$

## MORSA DE FIXAÇÃO LIVRE

Modelo: FV

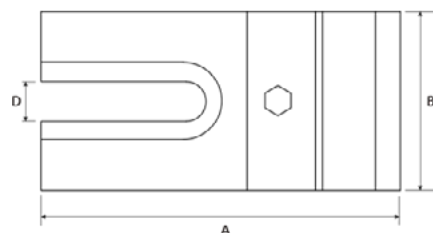
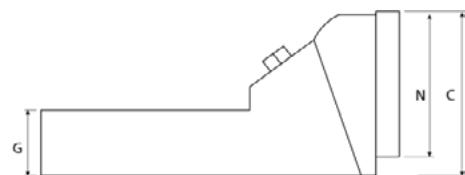

Código	Modelo	A	B	C	D	G	N	Força de aperto (Kn)
06625	FV-350	142	70	72	14.5	25	60	6.8
06626	FV-450	192.5	85	87	17	30	70	13

# MORSA DE PRECISÃO AUTOCENTRANTE AJUSTÁVEL

1. Usuário pode calibrar o centro de fixação da morsa, ajustando este parafuso.
2. Os mordentes são reversíveis para obter mais opções de abertura, fabricados em aço ferramenta de alta qualidade (SCM 440) e tratamento térmico de cementação para atingir 55HRC.
3. A força de aperto das morsas série ASC podem atingir em torno de 1300kg, a precisão de posicionamento de repetibilidade é de +/-0,02mm
4. O design da parte superior dos mordentes com dentes e cauda de andorinha de 45°, garantem que a parte inferior da peça de trabalho seja firmemente fixada.
5. O corpo da morsa é fabricado em aço de alta qualidade (S50C) e suas guias passaram por um tratamento térmico de alta frequência para atingir 50 HRC, garantido a sua durabilidade

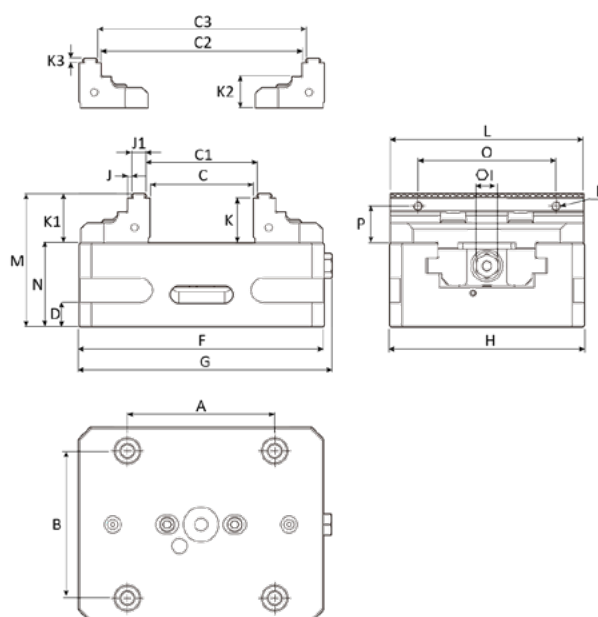
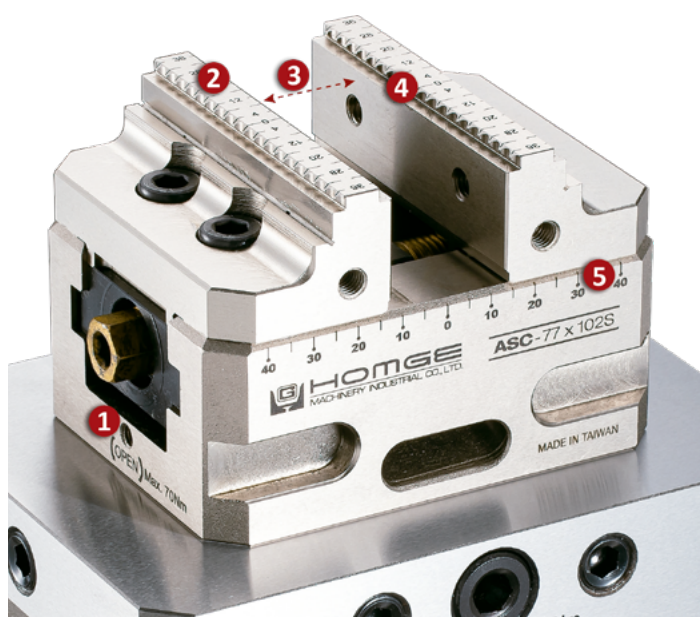

Código	Modelo	A	B	C	C1	C2	C3	D	E	F	G	H	OI	J
05882	ASC-77X130S	52	52	56	60	103	108	-	M6	130	135	77	12	2
05883	ASC-127X210S	96	96	120	125	181	186	16	M6	210	215	127	14	2.5
05884	ASC-127X260S	96	96	170	175	231	236	16	M6	260	265	127	14	2.5
06604	ASC-127X310S	96	96	220	225	281	286	16	M6	310	315	127	14	2.5
05885	ASC-160X310K	96	96	194	199	250	255	12	-	310	326	160	10	2.5

Código	Modelo	J1	K	K1	K2	K3	L	M	N	O	P	Pinos	Peso (Kg)
05882	ASC-77X130S	9.5	24	27	18	3	77	70	43	42	15	M-52X52PS	3.5
05883	ASC-127X210S	9.5	29	32	20	3	126	87	55	90	24	M-96X96PS	11
05884	ASC-127X260S	9.5	29	32	20	3	126	87	55	90	24	M-96X96PS	13
06604	ASC-127X310S	9.5	29	32	20	3	126	87	55	90	24	M-96X96PS	15
05885	ASC-160X310K	25	30	33	25	3	156	81	48	-	-	M-96X96PS	18

## PINO PARA ZERO POINT

Os pinos de tração para zero point, podem ser adaptados em morsas ou peças de trabalho, para serem utilizando juntamente com qualquer sistema de troca rápida zero point.



Código	Modelo
06607	M-52x52PS
06608	M-96x96PS

## SUPOORTE PARA ZERAMENTO DO ZERO POINT

Este dispositivo foi desenvolvido, para verificar e agilizar o alinhamento concêntrico dos dispositivos de troca rápida zero point e das morsas.



Código	Modelo	A	Ø B	C	D
06631	8010	80	35	27	52
06632	8058	126	35	27	96

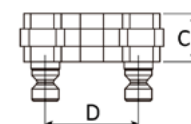
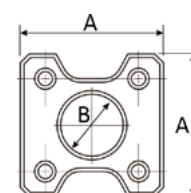

## ZERO POINT - PARA UMA MORSA

Repetibilidade: < 0,008 mm.

Espaçamento entre pinos de tração: 52 mm ou 96 mm.

Sistema de posicionamento rápido, preciso e flexível para centros de usinagem verticais, horizontais e máquinas com 4 ou 5 eixos.

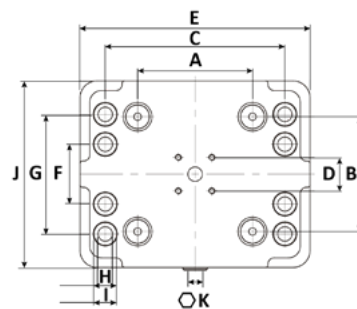

Código	Modelo	A	B	C	D	E	F	G	H	I	J	⊙K	Esp.
06605	8001	52	52	100	28	150	50	-	12	19	116	8	27
06606	8051	96	96	150	28	192	50	100	12	19	156	8	27

## ZERO POINT - PARA DUAS MORSAS

Estas bases múltiplas fornecem mais pontos para posicionamento, permitindo utilizar efetivamente os espaços das mesas das máquinas. Possibilitando fixar uma peça grande ou várias peças pequenas com posicionamento rápido e preciso.

7062

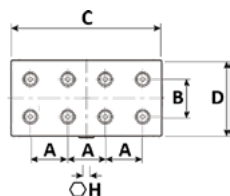

8062

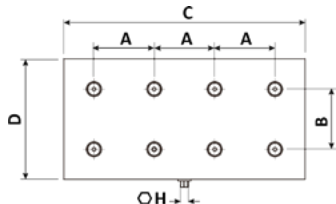

8067

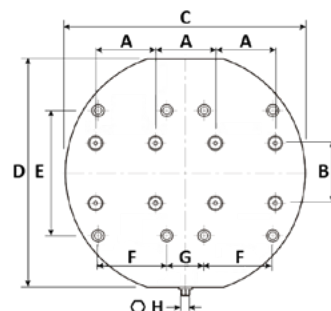

Código	Modelo	A	B	C	D	E	F	G	⊙H	Esp.
06613	7062	52	52	208	104	-	-	-	12	30
06614	8062	96	96	384	192	-	-	-	12	30
06615	8067	96	96	384	364	200	110	60	12	30

## ZERO POINT - BASE ELEVATÓRIA

Elevar a morσα ou a peça de trabalho para facilitar o processo de usinagem, evitando interferências e fornecer espaço suficiente para as ferramentas.

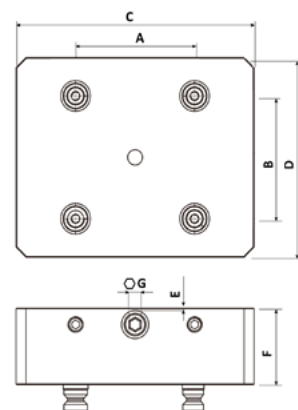

Código	Modelo	A	B	C	D	E	F	⊙G
06609	3131	52	52	150	116	3.65	60	8
06610	3133	52	52	150	116	3.65	100	8
06611	8222	96	96	192	156	1.8	60	8
06612	8226	96	96	192	156	1.8	100	8

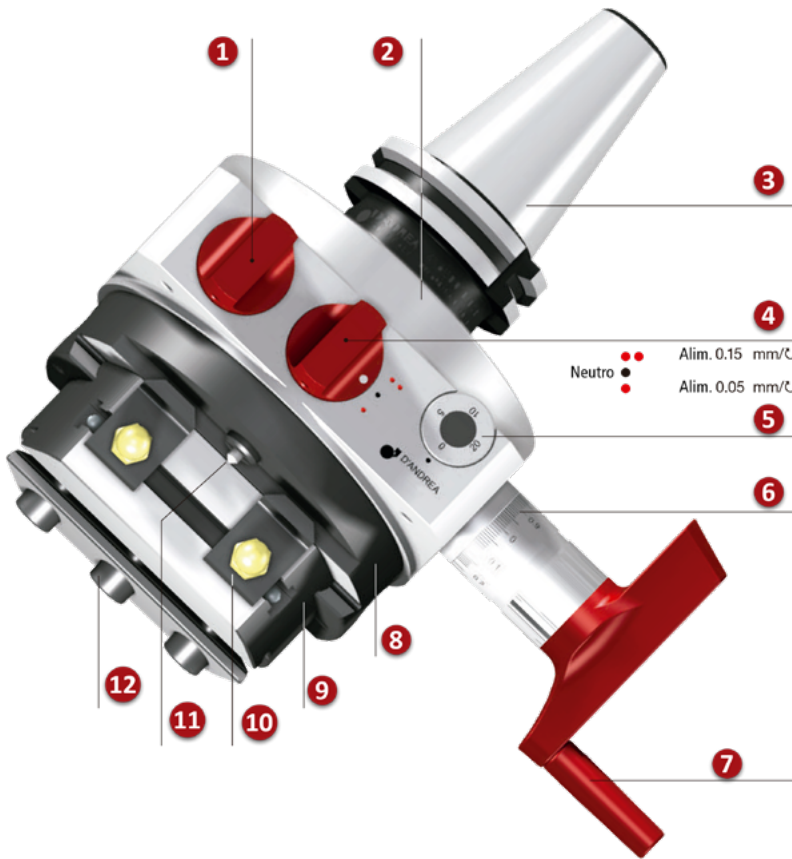

Cabeçotes de mandrilhar e facear, aplicáveis a fresadoras, mandrilhadoras e broqueadoras radiais, com possibilidade de ajustes manuais durante paragens da máquina e avanços automáticos durante a rotação do fuso da máquina.

É possível realizar operações de faceamento externo e interno, operações de recuo, mandrilamento cilíndrico e cônico, rasgos internos e externos, torneamento e chanfros.

O mandril é intercambiável e, graças ao adaptador MHD', permite o uso de todos os mandris disponíveis do sistema modular MHD'.

1. Botão de fixação para reajuste do nônio.
2. Corpo fixo
3. Acoplamento de mandris intercambiáveis MHD'
4. Taxas de alimentação do seletor
5. Nônio micrométrico
6. Nônio centesimal
7. Ajuste manual da manivela
8. Corpo rotativo
9. Corrediça porta-ferramentas
10. Bloco de parada ajustável
11. Desengate antecipado automático
12. Parafusos de travamento do porta ferramentas

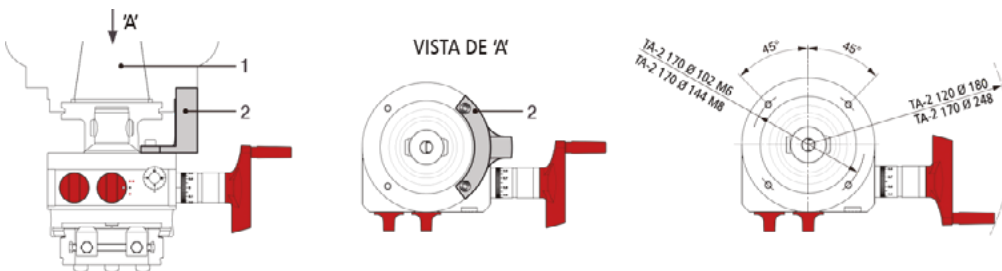

Aplicação: Os cabeçotes TA-S2 podem ser aplicados às máquinas-ferramentas através do mandril de acionamento (1) e do stop block (2). Para usinagem pesada, é recomendada a aplicação de uma flange.

**Stop block (2) não acompanha.**

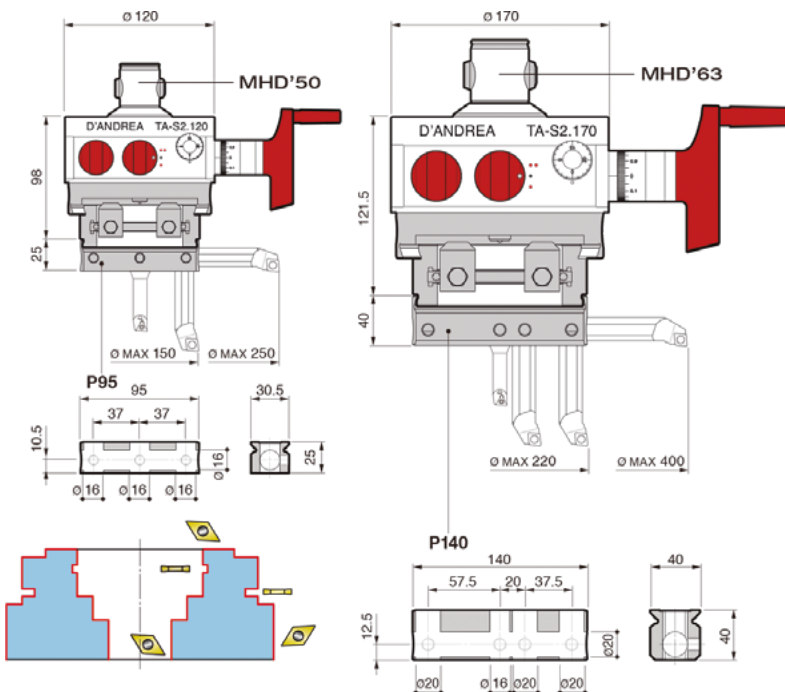

500212031001	Código	500217031001
K02 TA S2.120	Referência	K02 TA S2.170
250	Diâmetro máximo Ø (mm)	400
40	Deslocamento radial C (mm)	60
1000	Velocidade máxima (RPM)	800
6.5	Peso Líquido (Kg)	19
400	Torque (Nm)	800
2 - 6	Potência do motor (Kw)	3.5 - 11

P95 TA-S2.120	Suporte (Não incluso)	P140 TA-S2.120
433030300951	Código Suporte	433040401401

\* Item disponível somente sob encomenda

## CONE MODULAR CBH - LINHA DE MANDRILHAMENTO

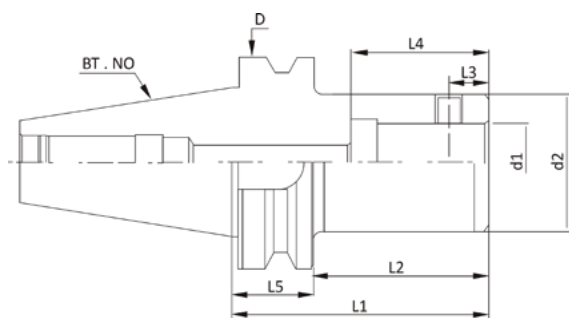
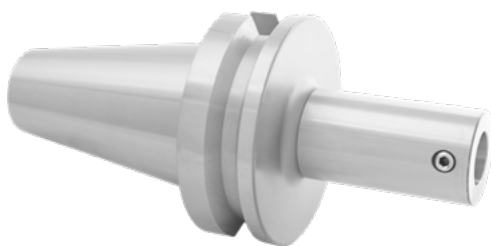

Código	Modelo	L1	L2	L3	L4	L5	D	d2	d1	Rosca
06269	BT50-CBH1-115	115	77	5.05	30	38	97.5	19	11	M4*0.5P
06270	BT50-CBH1-145	145	107	5.05	30	38	97.5	19	11	M4*0.5P
06271	BT50-CBH1-175	175	137	5.05	30	38	97.5	19	11	M4*0.5P
06272	BT50-CBH1-205	205	167	5.05	30	38	97.5	19	11	M4*0.5P
06273	BT50-CBH2-110	110	72	6.62	31	38	97.5	24	14	M5*0.5P
06274	BT50-CBH2-140	140	102	6.62	31	38	97.5	24	14	M5*0.5P
06275	BT50-CBH2-175	175	137	6.62	31	38	97.5	24	14	M5*0.5P
06276	BT50-CBH2-205	205	167	6.62	31	38	97.5	24	14	M5*0.5P
06277	BT50-CBH3-125	125	87	8	35	38	97.5	31	18	M6*0.75P
06278	BT50-CBH3-155	155	117	8	35	38	97.5	31	18	M6*0.75P
06279	BT50-CBH3-185	185	147	8	35	38	97.5	31	18	M6*0.75P
06280	BT50-CBH3-215	215	177	8	35	38	97.5	31	18	M6*0.75P
06281	BT50-CBH4-115	115	77	10	39	38	97.5	39	22	M8*0.75P
06282	BT50-CBH4-145	145	107	10	39	38	97.5	39	22	M8*0.75P
06283	BT50-CBH4-175	175	137	10	39	38	97.5	39	22	M8*0.75P
06284	BT50-CBH4-205	205	167	10	39	38	97.5	39	22	M8*0.75P
06285	BT50-CBH4-250	250	212	10	39	38	97.5	39	22	M8*0.75P
06286	BT50-CBH4-300	300	262	10	39	38	97.5	39	22	M8*0.75P
06287	BT50-CBH4-350	350	312	10	39	38	97.5	39	22	M8*0.75P
06288	BT50-CBH5-105	105	67	13	45	38	97.5	50	28	M10*1.0P
06289	BT50-CBH5-150	150	112	13	45	38	97.5	50	28	M10*1.0P
06290	BT50-CBH5-180	180	142	13	45	38	97.5	50	28	M10*1.0P
06291	BT50-CBH5-240	240	202	13	45	38	97.5	50	28	M10*1.0P
06292	BT50-CBH5-270	270	232	13	45	38	97.5	50	28	M10*1.0P
06293	BT50-CBH5-300	300	262	13	45	38	97.5	50	28	M10*1.0P
06294	BT50-CBH5-350	350	312	13	45	38	97.5	50	28	M10*1.0P
06295	BT50-CBH6-105	105	67	16	55	38	97.5	63	36	M12*1.0P
06296	BT50-CBH6-150	150	112	16	55	38	97.5	63	36	M12*1.0P
06297	BT50-CBH6-170	170	132	16	55	38	97.5	63	36	M12*1.0P
06298	BT50-CBH6-230	230	192	16	55	38	97.5	63	36	M12*1.0P
06299	BT50-CBH6-290	290	262	16	55	38	97.5	63	36	M12*1.0P
06300	BT50-CBH6-350	350	312	16	55	38	97.5	63	36	M12*1.0P
06301	BT50-CBH6-400	400	312	16	55	38	97.5	63	36	M12*1.0P
06302	BT50-CBH6-450	450	362	16	55	38	97.5	63	36	M12*1.0P
06303	BT50-CBH6-500	500	412	16	55	38	97.5	63	36	M12*1.0P

## PROLONGADOR MODULAR CBH

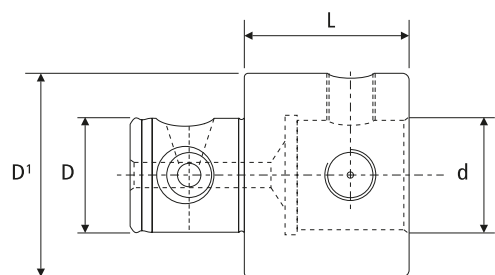

Código	Modelo	D	d	D1	L
06050	CBH1-1-30L	11	11	19	30
06051	CBH2-2-30L	14	14	24	30
06052	CBH3-3-30L	18	18	31	30
06053	CBH4-4-45L	22	22	39	50
06054	CBH5-5-60L	28	28	50	60
06055	CBH6-6-60L	36	36	63	60



# CONE MODULAR CBH - LINHA DE MANDRILHAMENTO

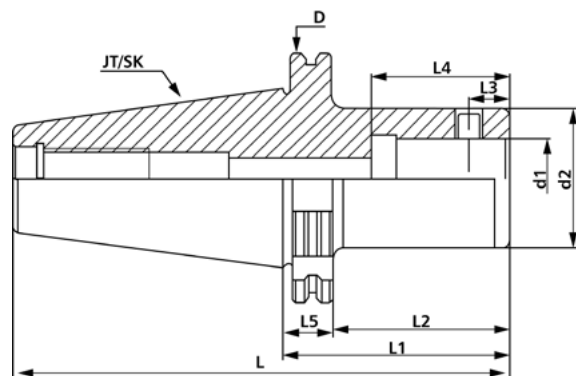
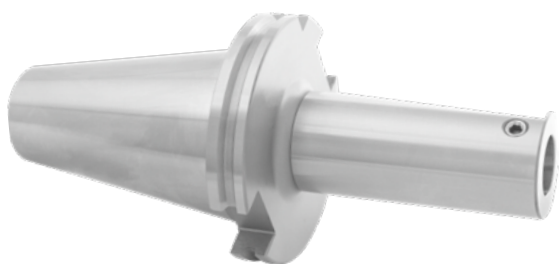

Código	Modelo	L1	L2	L3	L4	L5	D	d2	d1	Rosca
06304	SK50-CBH1-105	105	85.9	5.05	30	19.1	100	19	11	M4*0.5P
06305	SK50-CBH1-145	145	125.9	5.05	30	19.1	100	19	11	M4*0.5P
06306	SK50-CBH1-175	175	155.9	5.05	30	19.1	100	19	11	M4*0.5P
06307	SK50-CBH1-205	205	185.9	5.05	30	19.1	100	19	11	M4*0.5P
06308	SK50-CBH2-115	115	95.9	6.62	31	19.1	100	24	14	M5*0.5P
06309	SK50-CBH2-145	145	125.9	6.62	31	19.1	100	24	14	M5*0.5P
06310	SK50-CBH2-175	175	155.9	6.62	31	19.1	100	24	14	M5*0.5P
06311	SK50-CBH2-205	205	185.9	6.62	31	19.1	100	24	14	M5*0.5P
06312	SK50-CBH3-125	125	105.9	8	35	19.1	100	31	18	M6*0.75P
06313	SK50-CBH3-155	155	135.9	8	35	19.1	100	31	18	M6*0.75P
06314	SK50-CBH3-185	185	165.9	8	35	19.1	100	31	18	M6*0.75P
06315	SK50-CBH3-215	215	195.9	8	35	19.1	100	31	18	M6*0.75P
06316	SK50-CBH4-115	115	95.9	10	39	19.1	100	39	22	M8*0.75P
06317	SK50-CBH4-145	145	125.9	10	39	19.1	100	39	22	M8*0.75P
06318	SK50-CBH4-175	175	155.9	10	39	19.1	100	39	22	M8*0.75P
06319	SK50-CBH4-205	205	185.9	10	39	19.1	100	39	22	M8*0.75P
06320	SK50-CBH4-250	250	230.9	10	39	19.1	100	39	22	M8*0.75P
06321	SK50-CBH4-300	300	280.9	10	39	19.1	100	39	22	M8*0.75P
06322	SK50-CBH4-350	350	330.9	10	39	19.1	100	39	22	M8*0.75P
06323	SK50-CBH5-125	125	105.9	13	45	19.1	100	50	28	M10*1.0P
06324	SK50-CBH5-150	150	130.9	13	45	19.1	100	50	28	M10*1.0P
06325	SK50-CBH5-180	180	160.9	13	45	19.1	100	50	28	M10*1.0P
06326	SK50-CBH5-240	240	220.9	13	45	19.1	100	50	28	M10*1.0P
06327	SK50-CBH5-270	270	250.9	13	45	19.1	100	50	28	M10*1.0P
06328	SK50-CBH5-300	300	280.9	13	45	19.1	100	50	28	M10*1.0P
06329	SK50-CBH5-350	350	330.9	13	45	19.1	100	50	28	M10*1.0P
06330	SK50-CBH6-105	105	85.9	16	55	19.1	100	63	36	M12*1.0P
06331	SK50-CBH6-150	150	130.9	16	55	19.1	100	63	36	M12*1.0P
06332	SK50-CBH6-170	170	150.9	16	55	19.1	100	63	36	M12*1.0P
06333	SK50-CBH6-230	230	210.9	16	55	19.1	100	63	36	M12*1.0P
06334	SK50-CBH6-290	290	270.9	16	55	19.1	100	63	36	M12*1.0P
06335	SK50-CBH6-350	350	330.9	16	55	19.1	100	63	36	M12*1.0P
06336	SK50-CBH6-400	400	380.9	16	55	19.1	100	63	36	M12*1.0P
06337	SK50-CBH6-450	450	430.9	16	55	19.1	100	63	36	M12*1.0P
06338	SK50-CBH6-500	500	480.9	16	55	19.1	100	63	36	M12*1.0P

# CONE INDUÇÃO TÉRMICA - SHRINK FIT

(MAS 403 BT)



Figura 1



Figura 2

T.I.R  $\geq 5\mu\text{m}/2.5\text{x}D$  Bal./rpm G2.5/25.000RPM

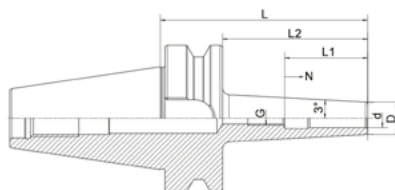
Código	Cone	Modelo	d	D	D1	L	L2	L1	N	G	Figura	Refrigeração	
03710	BT40	SFS03 - 100	3	9	-	100	73	-	-	-	1	AD	
03711		SFS04 - 100	4	10	-	100	73	-	-	-	1	AD	
03712		SFS05 - 90	5	11	-	90	63	-	-	-	1	AD	
03130		SFS06 - 90	6	12	-	90	63	36	10	M5	1	AD	
03131		SFS08 - 90	8	14	-	90	63	36	10	M6	1	AD	
03132		SFS10 - 90	10	16	-	90	63	42	10	M8x1	1	AD	
03133		SFS12 - 90	12	18	-	90	63	47	10	M10x1	1	AD	
03134		SFS14 - 90	14	20	-	90	63	47	10	M10x1	1	AD	
03135		SFS16 - 90	16	22	-	90	63	50	10	M12x1	1	AD	
03136		SF18 - 90	18	33	40	90	63	50	10	M12x1	2	AD	
03137		SF20 - 90	20	33	40	90	63	50	10	M16x1	2	AD	
03138		SF25 - 100	25	44	53	100	73	58	10	M16x1	2	AD	
03659		SF32 - 100	32	44	53	100	73	62	10	M16x1	2	AD	
06388		SFS03 - 160	3	9	-	160	133	-	-	-	1	AD	
06389		SFS04 - 160	4	10	-	160	133	-	-	-	1	AD	
06390		SFS06 - 160	6	12	-	160	133	36	10	M5	1	AD	
06391		SFS08 - 160	8	14	-	160	133	36	10	M6	1	AD	
06392		SFS10 - 160	10	16	-	160	133	42	10	M8x1	1	AD	
06393		SFS12 - 160	12	18	-	160	133	50	10	M10x1	1	AD	
06394		SFS16 - 160	16	22	-	160	133	50	10	M12x1	1	AD	
06395		SF06 - 200	6	21	32	200	173	36	10	M5	2	AD	
06396		SF08 - 200	8	21	32	200	173	36	10	M6	2	AD	
06397		SF10 - 200	10	24	34	200	173	42	10	M8x1	2	AD	
06398		SF12 - 200	12	24	34	200	173	47	10	M10x1	2	AD	
06399		SF14 - 200	14	27	42	200	173	47	10	M10x1	2	AD	
06400		SF16 - 200	16	27	42	200	173	50	10	M12x1	2	AD	
06401		BT50	SF06 - 100	6	21	27	100	62	36	10	M5	2	AD/B
06402			SF08 - 100	8	21	27	100	62	36	10	M6	2	AD/B
06403			SF10 - 100	10	24	30.5	100	62	42	10	M8x1	2	AD/B
06404			SF12 - 100	12	24	30.5	100	62	47	10	M10x1	2	AD/B
06405			SF14 - 100	14	27	34	100	62	47	10	M10x1	2	AD/B
06406			SF16 - 100	16	27	34	100	62	50	10	M12x1	2	AD/B
06407	SF18 - 100		18	33	40	100	62	50	10	M12x1	2	AD/B	
06408	SF20 - 100		20	33	40	100	62	52	10	M16x1	2	AD/B	
06409	SF25 - 120		25	44	53	120	82	58	10	M16x1	2	AD/B	
06410	SF32 - 120		32	44	53	120	82	62	10	M16x1	2	AD/B	
06411	SF04 - 160		4	15	25	160	122	-	-	-	2	AD/B	
06412	SF06 - 160		6	21	32	160	122	36	10	M5	2	AD/B	
06413	SF08 - 160		8	21	32	160	122	36	10	M6	2	AD/B	
06414	SF10 - 160		10	24	34	160	122	42	10	M8x1	2	AD/B	
06415	SF12 - 160		12	24	34	160	122	47	10	M10x1	2	AD/B	
06416	SF14 - 160		14	27	42	160	122	47	10	M10x1	2	AD/B	
06417	SF16 - 160		16	27	42	160	122	50	10	M12x1	2	AD/B	
06418	SF06 - 200		6	21	32	200	162	36	10	M5	2	AD/B	
06419	SF08 - 200		8	21	32	200	162	36	10	M6	2	AD/B	
06420	SF10 - 200		10	24	34	200	162	42	10	M8x1	2	AD/B	
06421	SF12 - 200		12	24	34	200	162	47	10	M10x1	2	AD/B	
06422	SF16 - 200		16	27	42	200	162	50	10	M12x1	2	AD/B	

Tabela de tolerância para hastas das ferramentas:

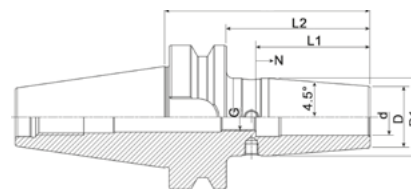
h6	Ø 3 - 6	Ø 6.1 - 10	Ø 10.1 - 14	Ø 14.1 - 18	Ø 18.1 - 24	Ø 24.1 - 30	Ø 30.1 - 40
		0 - 8 $\mu\text{m}$	0 - 9 $\mu\text{m}$	0 - 11 $\mu\text{m}$	0 - 11 $\mu\text{m}$	0 - 13 $\mu\text{m}$	0 - 13 $\mu\text{m}$



# CONE INDUÇÃO TÉRMICA - SHRINK FIT (DIN 69871)



Figura 1



Figura 2

T.I.R.  $\geq 5\mu\text{m}/2.5xD$  8al./rpm G2.5/25.000RPM

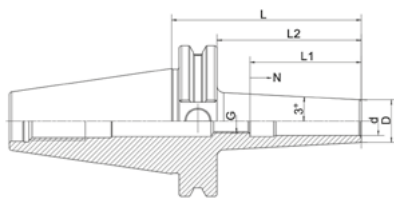
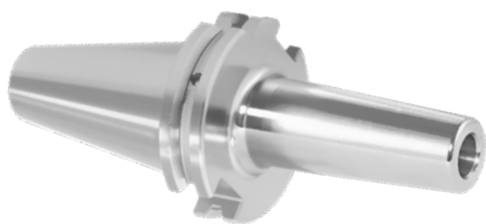
Código	Cone	Modelo	d	D	D1	L	L2	L1	N	G	Figura	Refrigeração
03951	SK - 40	SFS03 - 90	3	9	-	90	70.9	-	-	-	1	AD
03952		SFS04 - 90	4	10	-	90	70.9	-	-	-	1	AD
03953		SFS05 - 90	5	11	-	90	70.9	-	-	-	1	AD
03954		SFS06 - 90	6	12	-	90	70.9	36	10	M5	1	AD
03955		SFS08 - 90	8	14	-	90	70.9	36	10	M6	1	AD
03956		SFS10 - 90	10	16	-	90	70.9	42	10	M8x1	1	AD
03957		SFS12 - 90	12	18	-	90	70.9	47	10	M10x1	1	AD
03958		SFS14 - 90	14	20	-	90	70.9	47	10	M10x1	1	AD
03959		SFS16 - 90	16	22	-	90	70.9	50	10	M12x1	1	AD
06451		SK - 50	SFS03 - 160	3	9	-	160	140.9	-	-	-	1
06452	SFS04 - 160		4	10	-	160	140.9	-	-	-	1	AD
06453	SFS06 - 160		6	12	-	160	140.9	36	10	M5	1	AD
06454	SFS08 - 160		8	14	-	160	140.9	36	10	M6	1	AD
06455	SFS10 - 160		10	16	-	160	140.9	42	10	M8x1	1	AD
06456	SFS12 - 160		12	18	-	160	140.9	47	10	M10x1	1	AD
06457	SFS16 - 160		16	22	-	160	140.9	50	10	M12x1	1	AD
06458	SF06 - 80		6	21	27	80	60.9	36	10	M5	2	AD/B
06459	SF08 - 80		8	21	27	80	60.9	36	10	M6	2	AD/B
06460	SF10 - 80		10	24	31	80	60.9	42	10	M8x1	2	AD/B
06461	SF12 - 80	12	24	31	80	60.9	47	10	M10x1	2	AD/B	
06462	SF14 - 80	14	27	34	80	60.9	47	10	M10x1	2	AD/B	
06463	SF16 - 80	16	27	34	80	60.9	50	10	M12x1	2	AD/B	
06464	SF18 - 80	18	33	40	80	60.9	50	10	M12x1	2	AD/B	
06465	SF20 - 80	20	33	39.5	80	60.9	52	10	M16x1	2	AD/B	
06466	SF25 - 90	25	44	52.5	90	70.9	58	10	M16x1	2	AD/B	
06467	SF32 - 90	32	44	52.5	90	70.9	62	10	M16x1	2	AD/B	
06468	SF04 - 160	4	15	20	160	140.9	-	-	-	2	AD/B	
06469	SF06 - 160	6	21	32	160	140.9	36	10	M5	2	AD/B	
06470	SF08 - 160	8	21	32	160	140.9	36	10	M6	2	AD/B	
06471	SF10 - 160	10	24	34	160	140.9	42	10	M8x1	2	AD/B	
06472	SF12 - 160	12	24	34	160	140.9	47	10	M10x1	2	AD/B	
06473	SF14 - 160	14	27	42	160	140.9	47	10	M10x1	2	AD/B	
06474	SF16 - 160	16	27	42	160	140.9	50	10	M12x1	2	AD/B	
06475	SF06 - 200	6	21	32	200	180.9	36	10	M5	2	AD/B	
06476	SF08 - 200	8	21	32	200	180.9	36	10	M6	2	AD/B	
06477	SF10 - 200	10	24	34	200	180.9	42	10	M8x1	2	AD/B	
06478	SF12 - 200	12	24	34	200	180.9	47	10	M10x1	2	AD/B	
06479	SF14 - 200	14	27	42	200	180.9	47	10	M10x1	2	AD/B	
06480	SF16 - 200	16	27	42	200	180.9	50	10	M12x1	2	AD/B	

Tabela de tolerância para hastas das ferramentas:

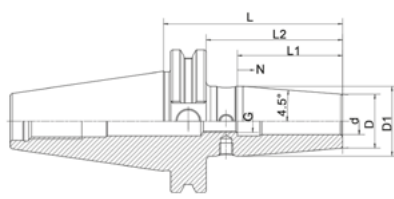
h6	Ø 3 - 6	Ø 6.1 - 10	Ø 10.1 - 14	Ø 14.1 - 18	Ø 18.1 - 24	Ø 24.1 - 30	Ø 30.1 - 40
		0 - 8 $\mu\text{m}$	0 - 9 $\mu\text{m}$	0 - 11 $\mu\text{m}$	0 - 11 $\mu\text{m}$	0 - 13 $\mu\text{m}$	0 - 13 $\mu\text{m}$

# CONE INDUÇÃO TÉRMICA - SHRINK FIT

(DIN 69893)



Figura 1



Figura 2

T.I.R.  $\geq 5\mu\text{m}/2.5xD$  Bal./rpm G2.5/25.000RPM

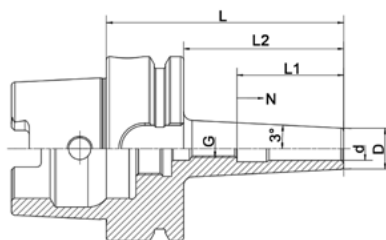
Código	Cone	Modelo	d	D	D1	L	L2	L1	N	G	Figura	Refrigeração
03875	HSK-A 63	SFS03 - 80	3	9	-	80	54	-	-	-	1	AD
03876		SFS04 - 80	4	10	-	80	54	-	-	-	1	AD
03877		SF05 - 80	5	15	-	80	54	-	-	-	1	AD
03878		SFS06 - 80	6	12	-	80	54	36	10	M5	1	AD
03879		SFS08 - 80	8	14	-	80	54	36	10	M6	1	AD
03880		SFS10 - 85	10	16	-	85	59	42	10	M8x1	1	AD
03881		SFS12 - 90	12	18	-	90	64	47	10	M10x1	1	AD
03882		SF14 - 90	14	27	-	90	64	50	10	M12x1	1	AD
03883		SFS16 - 95	16	22	-	95	69	50	10	M12x1	1	AD
03884		SFS18 - 95	18	33	41	95	69	50	10	M12x1	1	AD
03885		SFS20 - 100	20	33	42	100	74	52	10	M16x1	1	AD
03886		SFS25 - 115	25	44	52.5	115	89	58	10	M16x1	1	AD
06423		SFS03 - 160	3	9	-	160	134	-	-	-	1	AD
06424		SFS04 - 160	4	10	-	160	134	-	-	-	1	AD
06425		SFS06 - 160	6	12	-	160	134	36	10	M5	1	AD
06426		SFS08 - 160	8	14	-	160	134	36	10	M6	1	AD
06427		SFS10 - 160	10	16	-	160	134	42	10	M8x1	1	AD
06428		SFS12 - 160	12	18	-	160	134	47	10	M10x1	1	AD
06429	SFS16 - 160	16	22	-	160	134	50	10	M12x1	1	AD	
06430	SF06 - 200	6	21	32	200	174	36	10	M5	2	AD	
06431	SF08 - 200	8	21	32	200	174	36	10	M6	2	AD	
06432	SF10 - 200	10	24	34	200	174	42	10	M8x1	2	AD	
06433	SF12 - 200	12	24	34	200	174	47	10	M10x1	2	AD	
06434	SF14 - 200	14	27	42	200	174	47	10	M10x1	2	AD	
06435	SF16 - 200	16	27	42	200	174	50	10	M12x1	2	AD	
06436	HSK-A 100	SF06 - 85	6	21	26.5	85	56	36	10	M5	2	AD
06437		SF08 - 85	8	21	26.5	85	56	36	10	M6	2	AD
06438		SF10 - 90	10	24	30.5	90	61	42	10	M8x1	2	AD
06439		SF12 - 95	12	24	31	95	66	47	10	M10x1	2	AD
06440		SF14 - 95	14	27	34	95	66	47	10	M10x1	2	AD
06441		SF16 - 100	16	27	34	100	71	50	10	M12x1	2	AD
06442		SF18 - 100	18	33	41	100	71	50	10	M12x1	2	AD
06443		SF20 - 105	20	33	42	105	76	52	10	M16x1	2	AD
06444		SF25 - 115	25	44	53	115	86	58	10	M16x1	2	AD
06445		SF06 - 160	6	21	32	160	131	36	10	M5	2	AD
06446		SF08 - 160	8	21	32	160	131	36	10	M6	2	AD
06447		SF10 - 160	10	24	34	160	131	42	10	M8x1	2	AD
06448		SF12 - 160	12	24	34	160	131	47	10	M10x1	2	AD
06449		SF14 - 160	14	27	42	160	131	47	10	M10x1	2	AD
06450		SF16 - 160	16	27	42	160	131	50	10	M12x1	2	AD

Tabela de tolerância para hastas das ferramentas:

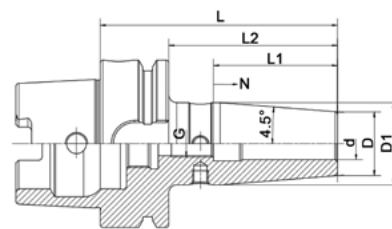
h6	Ø 3 - 6	Ø 6.1 - 10	Ø 10.1 - 14	Ø 14.1 - 18	Ø 18.1 - 24	Ø 24.1 - 30	Ø 30.1 - 40
		0 - 8 $\mu\text{m}$	0 - 9 $\mu\text{m}$	0 - 11 $\mu\text{m}$	0 - 11 $\mu\text{m}$	0 - 13 $\mu\text{m}$	0 - 13 $\mu\text{m}$

## PLACA AUTOCENTRANTE COM 3 CASTANHAS REVERSÍVEIS - FIXAÇÃO TRASEIRA

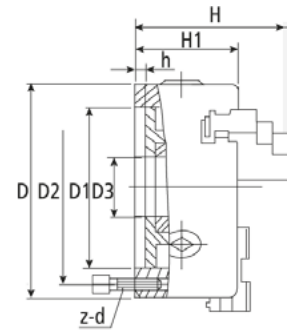
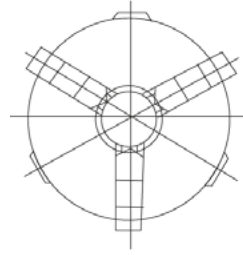

Código	Modelo	D	D1	D2	D3	H	H1	H2	h	z-d	Máx. R.P.M
06176	K11-630A	630	560	595	280	218	135	142	7	6-M16	600

## PLACA INDEPENDENTE COM 4 CASTANHAS MONOBLOCO

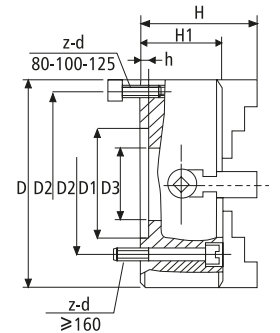
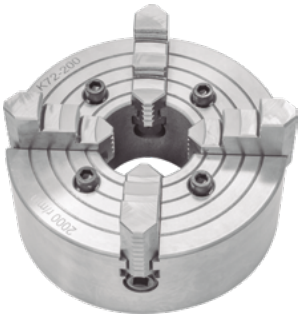

Código	Modelo	D	D1	D2	D3	H	H1	h	z-d	Máx. R.P.M
06343	K72-630	630	220	258	180	195	128	10	4-M20	500
06189	K72-800	800	250	300	220	225	145	12	8-M20	-
06344	K72-1000	1000	320	370	305	259	170	15	8-M20	-

## PLACA HIDRÁULICA DE PRECISÃO (0,003)

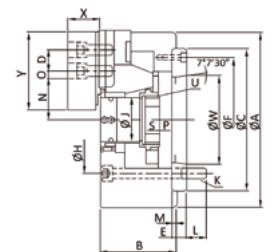
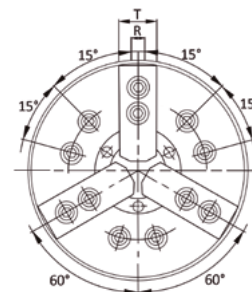

Código	Modelo	A	B	C	D	E	F	G	H	J	K	L	M	N	O	O
06365	PCP - 6	169	91	140	20	15	82.563	116	104.8	45	6-M10	16	5	32	24	7
06366	PCP - 8	210	103	170	25	17	106.375	150	133.4	52	6-M12	18	5	39	30	11
06367	PCP - 10	254	113	220	30	18	139.719	190	171.4	75	6-M16	24	5	51	33.75	14.25

Código	Modelo	P	P	Q	R	S	T	U	V	W	X	Y
06365	PCP - 6	25	14	2	12	19	31	M55x2	3-M6	60	37.5	73
06366	PCP - 8	31.5	15.5	2	14	20.	35	M60x2	3-M6	66	39	95
06367	PCP - 10	26.5	7.5	2	16	25	40	M85x2	3-M8	94	43	110

## PLACA HIDRÁULICA

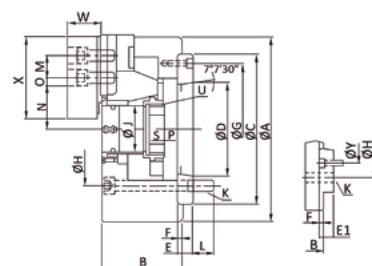
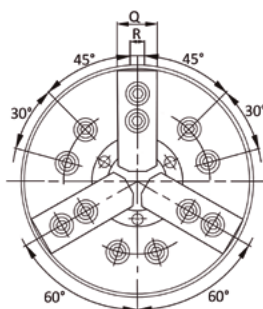

Código	Modelo	A	B	C	D	E	E1	F	G	H	J	K	L	M
06134	OCHC-10	254	100	220	139.719	18	28	5	190	171.4	75	6-M16x2.0P	19	30

Código	Modelo	N	N	O	O	P	P	Q	R	S	U	W	X	Y
06134	OCHC-10	51.5	47.1	34	12	8.5	-10.5	40	16	25	M85x2P	48	110	133.4

## PLACA 3 CASTANHAS - COMBINADA (AUTO. E INDEP.)



- A placa combinada com 3 castanhas pode centralizar todas as castanhas de forma autocentrante através de um dos pinhões e também de forma independente com o pinhão de ajuste fino, localizado abaixo da castanha, permitindo centralizar a peça de trabalho com alta precisão combinada.
- Este modelo de placa é indicado para usinagem de componentes excêntricos e com formatos especiais.

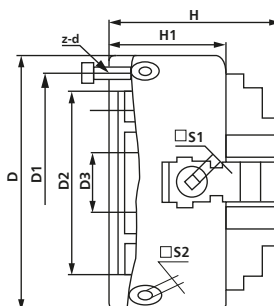
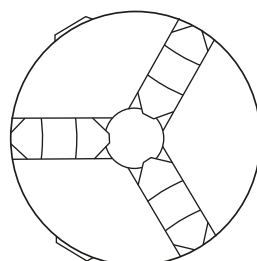

Código	Modelo	D	D1	D2	D3	H1	H	h	S1	S2	z-d	Peso (Kg)
06381	K90-160	160	130	142	42	87	115	5	10	8	3-M8	11
06382	K90-200	200	165	180	65	97	127	5	12	10	3-M10	18
06383	K90-250	250	206	226	80	102	142	5	12	10	3-M12	29
06384	K90-325	325	272	296	100	120	163	6	13	12	3-M16	46

## PLACA 4 CASTANHAS - COMBINADA (AUTO. E INDEP.)



- A placa combinada com 4 castanhas pode centralizar todas as castanhas de forma autocentrante através de um dos pinhões e também de forma independente com o pinhão de ajuste fino, localizado abaixo da castanha, permitindo centralizar a peça de trabalho com alta precisão combinada.
- Este modelo de placa é indicado para usinagem de componentes excêntricos e com formatos especiais.

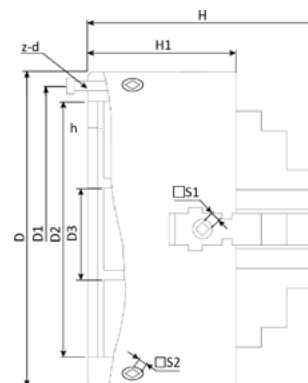

Código	Modelo	D	D1	D2	D3	H1	H	h	S1	S2	z-d	Peso (Kg)
06543	K92-160	160	130	142	42	87	115	5	10	8	3-M8	11
06544	K92-200	200	165	180	65	97	127	5	12	10	3-M10	18
06545	K92-250	250	206	226	80	102	142	5	12	10	3-M12	29

# PLACA PNEUMÁTICA - PARA OPERAÇÕES EM MÁQUINAS COM MESA

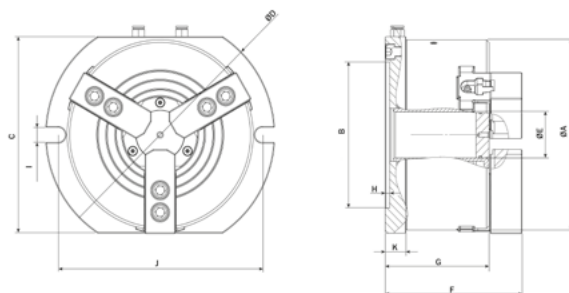

## Dimensões do produto:

Código	Modelo	A	B	C	D	E	F	G	H	I	J	K
06350	PPC-8	215	165	222	265	52	158	120	5	2-17	236	24
06351	PPC-10	256	206	270	310	70	169	126	5	2-17	280	24

## Performance do produto:

Código	Modelo	Curso das Castanhas	Força máxima de fixação estática (kgf)	Força máxima de retenção estática (kgf)	Pressão permitida	Fixação	Retenção	Peso (Kg)
06350	PPC-8	5.5	52(5320)	58(5940)	0.4-0.8	5-220	20-240	33
06351	PPC-10	6	69(7043)	82(8400)	0.4-0.8	10-260	30-280	46

# MESA COORDENADA

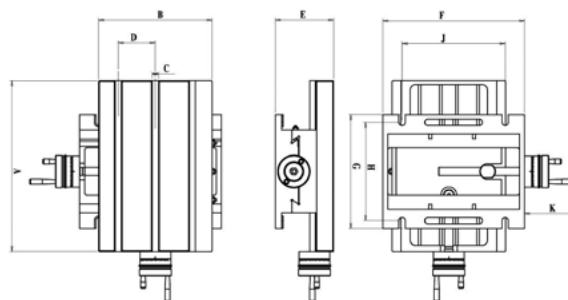
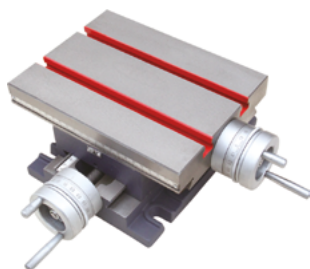

Código	Modelo	A	B	C	D	E	F	G	H	J	K	Deslocamento em X	Deslocamento em Y	Peso (Kg)
06357	CST-21	185	100	10	35	102	170	130	115	100	96	80	50	10
06358	CST-22	225	175	12	72	108	225	175	148	160	96	105	90	15
06359	CST-23	330	220	12	72	115	275	220	190	200	96	190	100	24
06360	CST-24	425	240	12	72	125	335	276	240	245	144	225	150	41
06361	CST-25	600	240	12	72	125	335	276	240	245	144	400	150	51

# BORRACHA PARA MESA DE TRABALHO

- Resistente a altas fontes de calor.
- Resistente a cortes e rasgos.
- Fácil aplicação
- Personalizável

Para maiores informações escaneie o Qr code ao lado

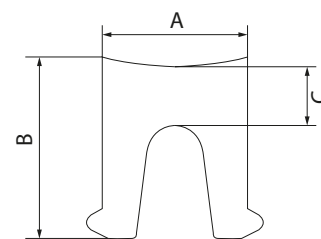
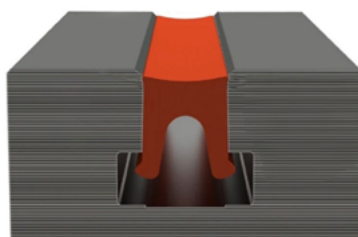
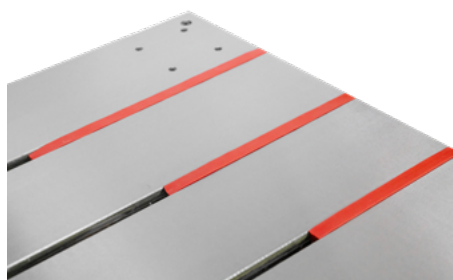

Código	Modelo	A	B	C	Rasgo
06518	STZ-14	14	17	4.5	M12
06519	STZ-16	16	19	6.5	M14
06520	STZ-18	18	20	5.5	M16
06521	STZ-22	22	22.5	6	M20

## FERRAMENTA ACIONADA BMT - AXIAL (DIN 1809)

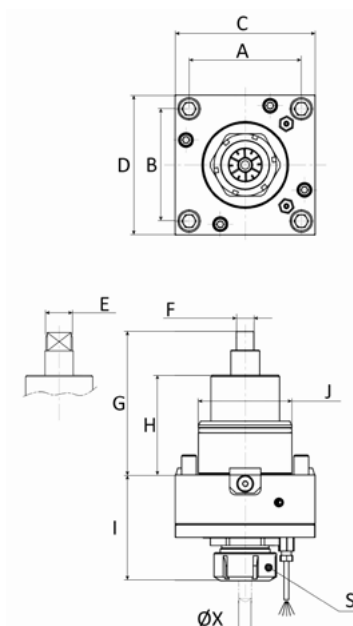

Código	Modelo	Pinça (S)	A	B	C	D	E	F	G	H	I	J	Ø S	T (Nm)	Max. RPM
06559	BMT 40-7504 - AX	ER-32	70	62	110	92	21	8	69	42	64	39.9	Ø2-20	40	6000
06192	BMT 45-7001 - AX	ER-25	58	58	75	75	14	6	84	60	58	75	Ø1-16	25	8000
06194	BMT 55-7136 - AX	ER-25	64	64	85	85	15	8	104	75	61	85	Ø1-16	40	8000
06195	BMT 55-7137 - AX	ER-32	64	64	85	85	15	8	104	75	62	85	Ø2-20	40	8000
06563	BMT 60-7609 - AX	ER-40	94	84	130	108	23.7	8	91	53	94	59.9	Ø3-26	70	10000
06197	BMT 65-7223 - AX	ER-32	70	73	94	94	18	10	112	83	66	94	Ø2-20	70	6000
06569	BMT 68-8101 - AX	ER-32	110	68	128	85	12	23	90	34	72	68	Ø2-20	70	6000
06199	BMT 75-7303 - AX	ER-40	90	90	112	112	23	14	110	80	90	112	Ø3-26	100	4000

## FERRAMENTA ACIONADA BMT - RADIAL (DIN 1809)

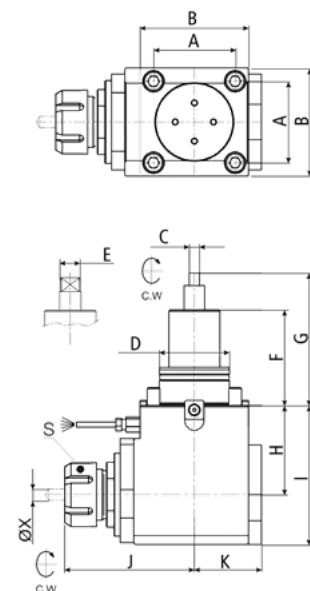
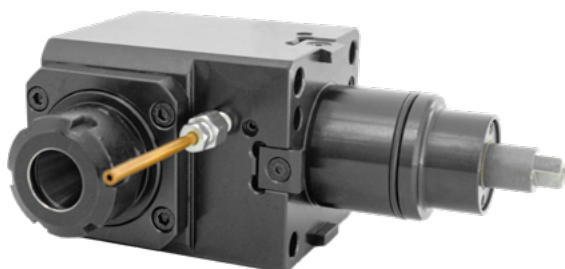

Código	Modelo	Pinça (S)	A	B	C	D	E	F	G	H	I	J	K	ØX	T (Nm)	Max. RPM
06560	BMT 40-7506 - RD	ER-32	62	70	8	39.9	21	55	69	85	122	96	65	Ø2-20	25	5000
06193	BMT 45-7002 - RD	ER-25	58	75	6	45	14	60	84	65	95	85	51.5	Ø1-16	25	8000
06196	BMT 55-7135 - RD	ER-25	64	85	8	55	15	75	104	85	119	101	52.5	Ø2-20	40	6000
06564	BMT 60-7611 - RD	ER-40	84	94	8	59.9	23.7	74.5	91	90	130	114	68	Ø3-26	70	10000
06198	BMT 65-7220 - RD	ER-32	70	94	10	65	18	83	112	72	110	96	57.5	Ø2-20	70	6000
06570	BMT 68-8102 - RD	ER-32	68	110	12	68	23	80	90	80	114	97.2	60	Ø2-20	70	6000
06200	BMT 75-7311 - RD	ER-40	90	112	14	75	23	80	110	110	155	105.5	64	Ø3-30	100	4000



## FERRAMENTA ACIONADA VDI- AXIAL (DIN 1809)

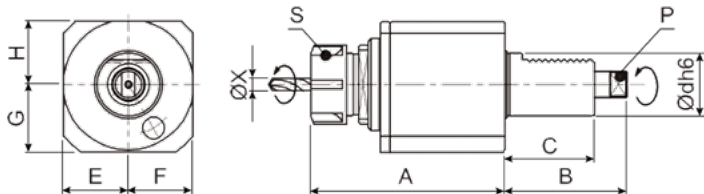
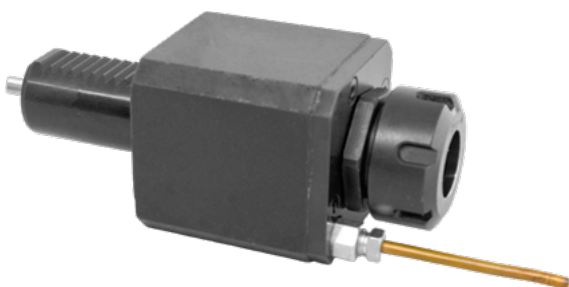

Código	Modelo	Ødh6	A	B	C	E	F	G	H	ØX	S (DIN 6499)	i	Max. RPM	T (Nm)	P
06201	VDI 30 - 6124 AX	30	98.5	62	50.5	30	30	30	28	1-16	ER-25	1:1	6000	40	Ø12x6x7
06202	VDI 40 - 6236 AX	40	123	72	56	41	41	43	40	2-20	ER-32	1:1	5000	70	Ø14x8x8

## FERRAMENTA ACIONADA VDI- RADIAL (DIN 1809)

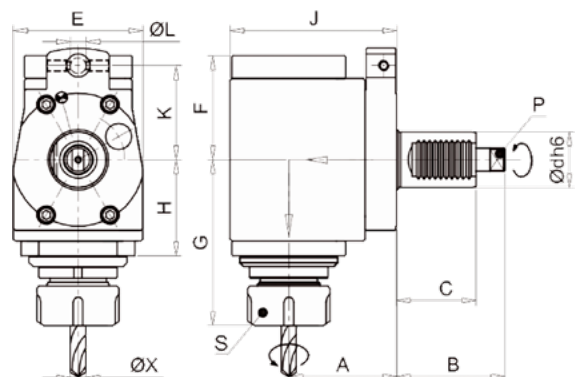

Código	Modelo	Ødh6	A	B	C	E	F	G	H	J	K	ØL	ØX	S (DIN 6499)	i	Max. RPM	T (Nm)	P
06203	VDI 30 - 6142 RD	30	55	62	50.5	66	53	84.5	41.5	85	40	8	1-16	ER-25	1:1	6000	40	Ø12x6x7
06204	VDI 40 - 6241 RD	40	64	72	56	76	69	90	43	98	63	10	2-20	ER-32	1:1	5000	70	Ø14x8x8

## FERRAMENTA ACIONADA VDI- AXIAL (DIN 5480)

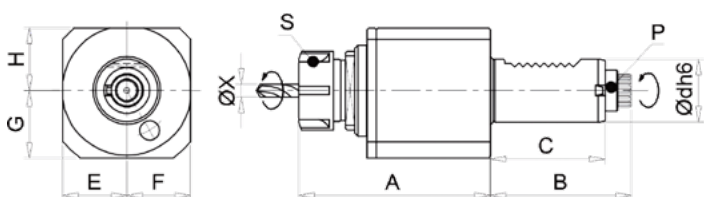

Código	Modelo	Ødh6	A	B	C	E	F	G	H	ØX	S (DIN 6499)	i	Max. RPM	T (Nm)	P
06205	VDI 30 - 6111 AX	30	98.5	67	55	30	30	30	28	1-16	ER-25	1:1	6000	40	W16x0.8x30°x18-9b
06206	VDI 40 - 6207 AX	40	123	75	63	41	41	43	40	2-20	ER-32	1:1	5000	70	W20x0.8x30°x24-9b



## FERRAMENTA ACIONADA VDI- RADIAL (DIN 5480)

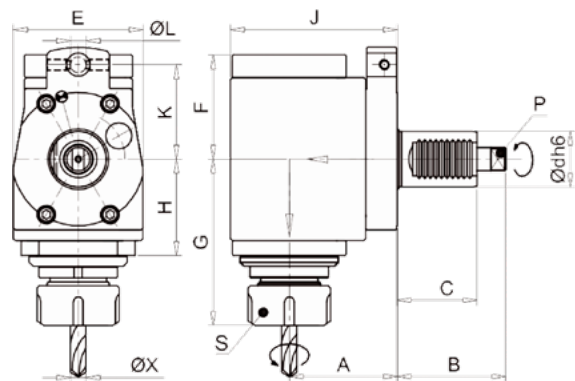

Código	Modelo	Ødh6	A	B	C	E	F	G	H	J	K	ØL	ØX	S (DIN 6499)	i	Max. RPM	T (Nm)	P
06207	VDI 30 - 6130 RD	30	55	67	55	66	53	84.5	41.5	85	48	8	1-16	ER-25	1:1	6000	40	W16x0.8x30°x18-9b
06208	VDI 40 - 6221 RD	40	64	75	63	76	69	90	43	98	56	10	2-20	ER-32	1:1	5000	70	W20x0.8x30°x24-9b

## FERRAMENTA ACIONADA VDI- AXIAL (DIN 5482)

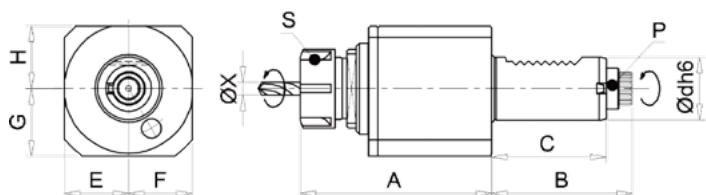

Código	Modelo	Ødh6	A	B	C	E	F	G	H	ØX	S (DIN 6499)	i	Max. RPM	T (Nm)	P
06209	VDI 30 - 6112 AX	30	98.5	55	45	30	30	30	28	1-16	ER-25	1:1	6000	40	B15x12-9b
06210	VDI 40 - 6202 AX	40	123	63	53	41	41	43	40	2-20	ER-32	1:1	5000	70	B17x14-9b

## FERRAMENTA ACIONADA VDI- RADIAL (DIN 5482)

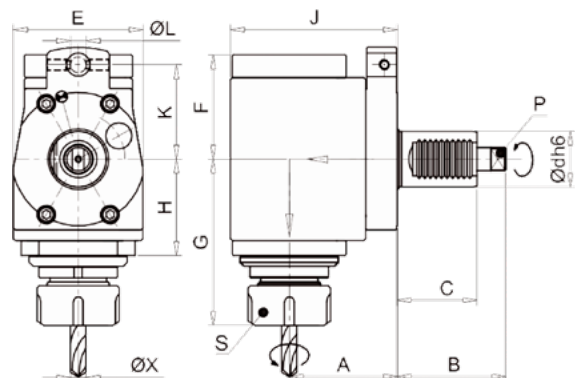

Código	Modelo	Ødh6	A	B	C	E	F	G	H	J	K	ØL	ØX	S (DIN 6499)	i	Max. RPM	T (Nm)	P
06211	VDI 30 - 6115 RD	30	55	55	45	66	53	84.5	41.5	85	40	8	1-16	ER-25	1:1	6000	40	B15x12-9b
06212	VDI 40 - 6215 RD	40	64	63	53	76	74	90	43	98	63	10	2-20	ER-32	1:1	5000	70	B17x14-9b

## BMT - FRONTAL

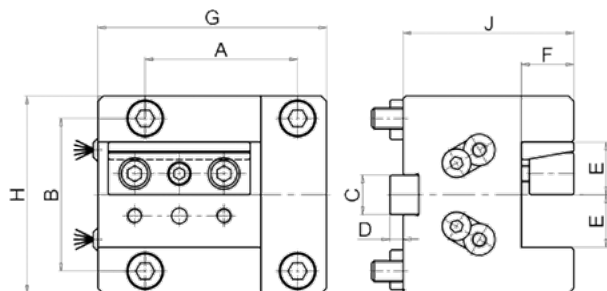

Código	Modelo	A	B	C	D	E	F	G	H	J
06556	BMT 40 - B1 - 25 - L115	70	62	39.9	-	25	25	115	90	85
06213	BMT 45 - B1 - 20 - L 87	58	58	15	5	20	20	87	75	65
06214	BMT 55 - B1 - 25 - L105	64	64	15	5	25	25	105	86	70
06562	BMT 60 - B1 - 25 - L130	94	84	59.9	-	25	25	130	108	90
06215	BMT 65 - B1 - 25 - L105	70	73	18	5	25	25	105	96	95
06566	BMT 68 - B1 - 25 - L140	110	68	68	-	25	25	140	98	98
06216	BMT 75 - B1 - 25 - L140	90	90	25	6	25	25	140	112	70
06217	BMT 75 - B1 - 32 - L135	90	90	25	6	32	32	135	112	60

## BMT - LATERAL

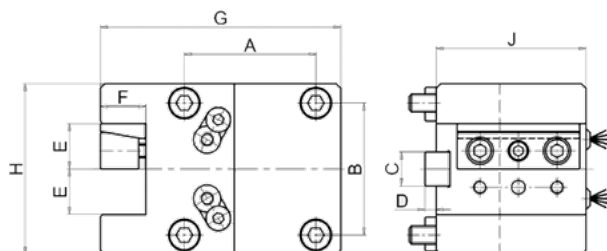

Código	Modelo	A	B	C	D	E	F	G	H	J
06558	BMT 40 - C1 - 25 - L120	70	62	39.9	-	25	25	120	90	70
06218	BMT 45 - C1 - 20 - L102	58	58	15	5	20	20	102	75	66
06219	BMT 55 - C1 - 25 - L120	64	64	15	5	25	25	120	86	60
06220	BMT 65 - C1 - 25 - L130	70	73	18	5	25	25	130	96	75
06568	BMT 68 - C1 - 20 - L143	110	68	68	-	20	20	143	98	80
06221	BMT 75 - C1 - 25 - L145,5	90	90	25	6	25	25	145.5	112	85
06222	BMT 75 - C1 - 32 - L150,5	90	90	25	6	32	32	150.5	112	85

## BMT - LATERAL DUPLO INV.

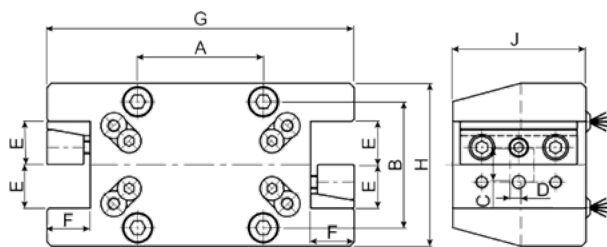

Código	Modelo	A	B	C	D	E	F	G	H	J
06232	BMT 45 - CD2 - 20 - 164	58	58	15	5	20	20	164	75	66
06233	BMT 55 - CD2 - 25 - 188	64	64	15	5	25	25	188	86	80

## BMT - LATERAL DUPLO

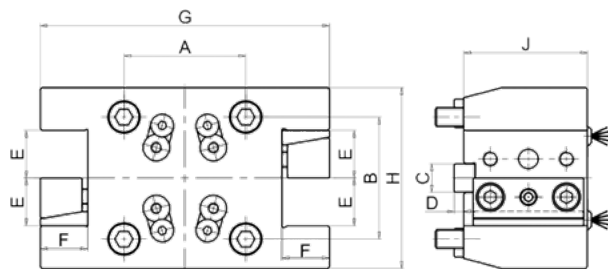

Código	Modelo	A	B	C	D	E	F	G	H	J
06228	BMT 45 - CD1 - 20 - 132	58	58	15	5	20	20	132	75	60
06229	BMT 55 - CD1 - 25 - 152	64	64	15	5	25	25	152	95	65
06230	BMT 65 - CD1 - 25 - 149	70	73	18	5	25	25	149	96	80
06231	BMT 75 - CD1 - 32 - 181	90	90	25	6	32	32	181	112	85

## BMT - LATERAL INV.

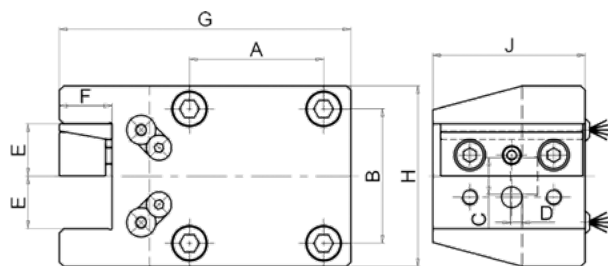

Código	Modelo	A	B	C	D	E	F	G	H	J
06223	BMT 45 - C2 - 20 - 127	58	58	15	5	20	20	127	75	66
06224	BMT 55 - C2 - 25 - 139	64	64	15	5	25	25	139	86	80
06225	BMT 65 - C2 - 25 - 150	70	73	18	5	25	25	150	96	75
06226	BMT 75 - C2 - 25 - 165	90	90	25	6	25	25	165	112	100
06227	BMT 75 - C2 - 32 - 168	90	90	25	6	32	32	168	112	100

## BMT - PORTA FERRAMENTA

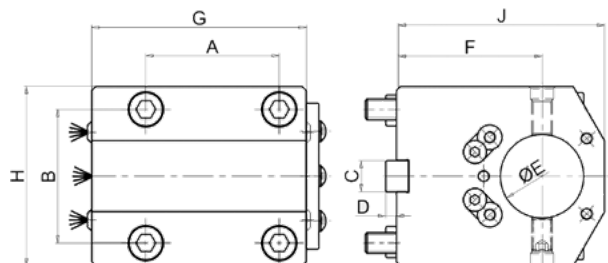

Código	Modelo	A	B	C	D	Ø E	F	G	H	J
06557	BMT 40 - T2 - 32 - F100 - L	70	62	39.9	15	-	-	115	90	85
06234	BMT 45 - T2 - 32 - F65 - L	58	58	15	5	32	65	95	75	95
06235	BMT 55 - T2 - 40 - F70 - L	64	64	15	5	40	70	103	86	100
06236	BMT 55 - T2 - 40 - F70 - L1	64	64	15	5	40	70	120	86	100
06561	BMT 60 - T2 - 40 - F80 - L	94	84	59.9	-	40	80	135	108	120
06237	BMT 65 - T2 - 40 - F72 - L1	70	73	18	5	40	72	127	96	102
06238	BMT 65 - T2 - 40 - F100 - L1	70	73	18	5	40	100	127	96	135
06567	BMT 68 - T2 - 40 - F140 - L	110	68	68	24	40	95	140	-	123
06239	BMT 75 - T2 - 50 - F60 - L1	90	90	25	6	50	60	165	112	110
06240	BMT 75 - T2 - 50 - F110 - L1	90	90	25	6	50	110	137	112	155

## SUPORTE CASTELO - PORTA FERRAMENTA

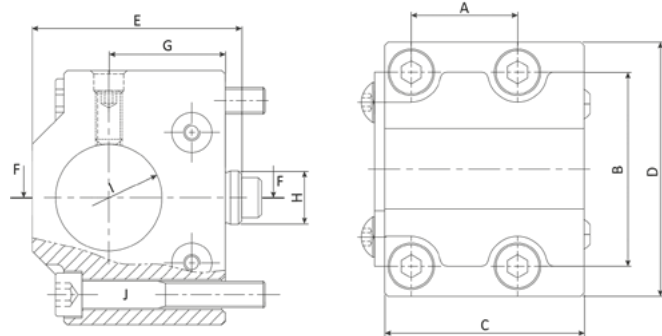

Código	Modelo	A	B	C	D	E	G	H	Ø I	J
06551	CD 32X58 - 32 - 25	32	58	60	76	57	25	16	32	M8x45
06550	CD 32X58 - 32 - 35	32	58	60	76	63	35	16	32	M8x55
06602	CD 36X72 - 32 - 30	36	72	80	92	64	30	25	32	M10x55
06603	CD 36X72 - 40 - 30	36	72	80	92	64	30	25	40	M10x55
06553	CD 45X70 - 32 - 25,4	45	70	77.2	90	49.92	25.4	-	32	-
06575	CD 45X72 - 40 - 35	45	72	85	93	65	35	20	40	M10x55
06554	CD 45X80 - 40 - 30	45	80	82.55	101.6	-	30	-	40	M12x55
06565	CD 45X80 - 40 - 31,7	45	80	82.55	101.6	-	31.75	-	40	M12x55
06577	CD 45X80 - 40 - 60	45	80	125	-	97	60	20	40	-
06572	CD 60X84 - 40 - 50	60	84	80	104	79	50	38	40	-
06574	CD 60X94 - 40 - 50	60	94	100	114	80	50	38	40	M8x45

## SUPORTE CASTELO - FRONTAL

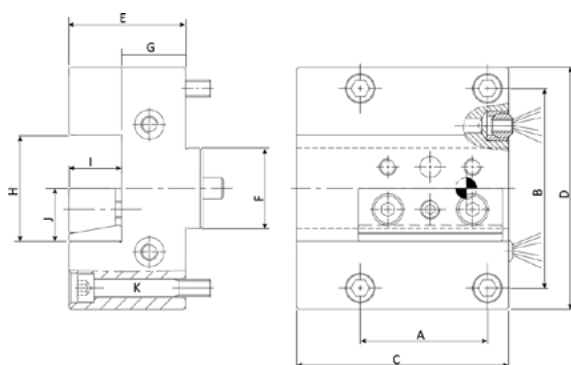

Código	Modelo	A	B	C	D	E	F	G	H	I	J	K
06549	CF 32X58 - 20	32	58	60	76	45	16	25	40	20	20	M8x45
06601	CF 36X72 - 25	36	72	80	92	55	25	30	50	25	25	-
06552	CF 45X70 - 25	45	70	77.2	90	45	15	20	50	25	25	M10X50
06555	CF 45X80 - 25	45	80	82.55	101.6	58.17	-	33.17	50	25	25	M12X55
06576	CF 45X80 - 25	45	80	125	102	50	20	25	50	25	25	M12
06600	CF 55X80 - 25	55	80	96	102	50	20	-	50	-	25	M12X55
06571	CF 60X84 - 25	60	84	80	104	63	38	38	50	25	25	M8
06573	CF 60X94 - 25	60	94	100	114	55	38	30	50	25	25	M8X55



## GRAMPO BAR PULLER

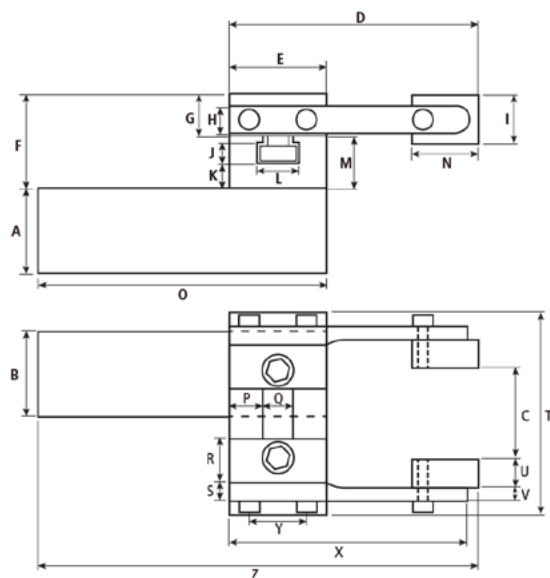
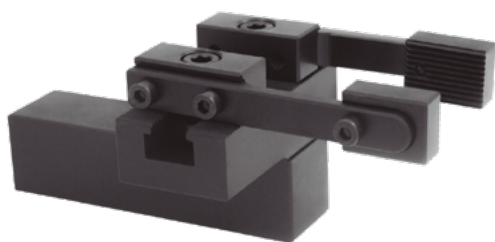

Código	Modelo	A	B	C Mínimo	C Máximo	D	E	F	G	H	I	J
06386	20MM	20	20	0	40	82	32	32,5	13,2	10	16	6,7
06387	25MM	25	25	0	40	82	32	32,5	13,2	10	16	6,7

K	L	M	N	O	P	Q	R	S	T	U	V	X	Y	Z
8,5	14	18	22	75,2	11	10	20	6	67	9,1	4,2	79	19	82
8,5	14	18	22	95	11	10	20	6	67	9,1	4,2	79	19	141,5

## BUCHA PROLONGADORA (DIN 2187)

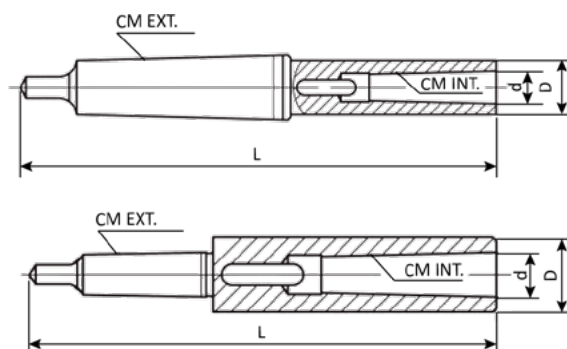

Código	Modelo	Cone Morse Externo	Cone Morse Interno	D	d	L
06590	BP3-2	3	2	30	17.780	194
06591	BP3-3	3	3	36	23.825	215
06592	BP3-4	3	4	48	31.267	240
06593	BP4-2	4	2	30	17.780	215
06594	BP4-3	4	3	36	23.825	240
06595	BP4-4	4	4	48	31.267	265
06596	BP4-5	4	5	63	44.399	300
06597	BP5-3	5	3	36	23.825	268
06598	BP5-4	5	4	48	31.267	300
06599	BP5-5	5	5	63	44.399	335

## PORCA "T"

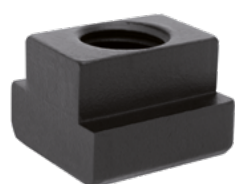

PT-0005

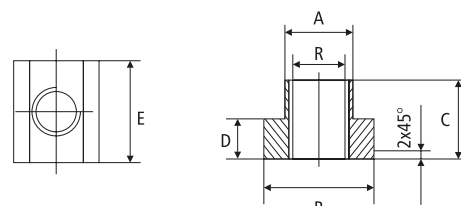

Medidas em: mm

Código	R	A	B	C	D	E
00566	M 12 x 1,75	17,7	28	20	10	28
03402	M 16 x 2,00	21,7	35	28	14	35



## CABEÇOTE ANGULAR 90° (MAS 403 BT)

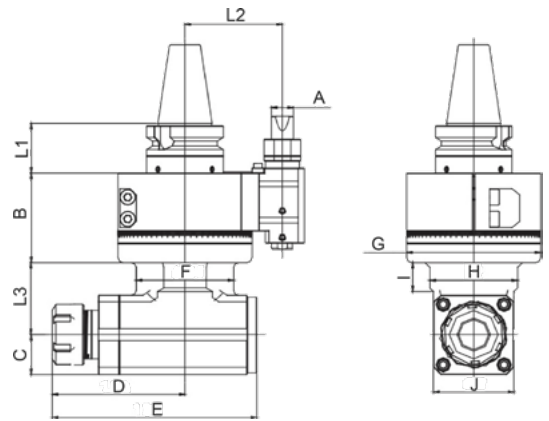

Código	Modelo	A	B	C	D	E	F	G	H	I	J	L1	L2	L3	Torque	Rotação (RPM)
06368	AH90-ER-16	18	62	21	69.5	109.5	55	90	46	40	42	37	65	72	12 Nm	5.000
06369	AH90-ER-25	22	70	35	80	128	107	107	67	24	67	55	65	65	32 Nm	5.000
04680	AH90-ER-32	22	60	35	85	147	108	110	76	24	70	43	80	60	40 Nm	4.500
06370	AH90-ER-40	18	79	38	126.5	186.5	90	120	82	24	76	45	80	230	75 Nm	4.000

## ADAPTADOR PARA TROCA RÁPIDA - Sem Embreagem de Segurança

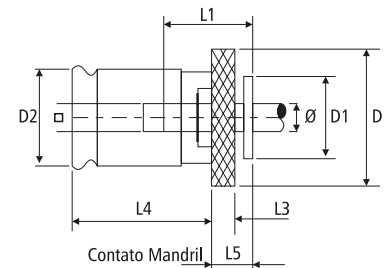
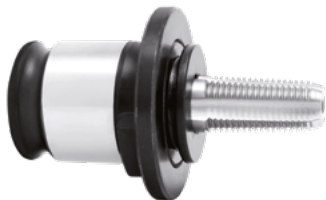

Modelo	Haste $\varnothing$	Mandril Indicado	D dia.	D1 dia.	D2 dia.	L1	L3	L4	L5
KWES/1	3.5 - 11.3	1	30	19	19	17	4	21.5	8
KWES/2	7.0 - 18.0	2	48	30	31	30	5	35.0	11
KWES/3	11 - 28	3	70	38	48	44	6	55.5	15

Código	Modelo	$\varnothing$	$\nabla$	Roscas
06341	KWES/3	28.58	21.41	(1 NPT)

## PONTO ROTATIVO



Ponto Rotativo utiliza a combinação de rolamento de esferas e rolamento de pressão.

Série D4 indicada somente para máquinas convencionais, com carga média.

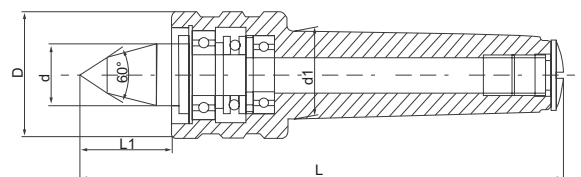
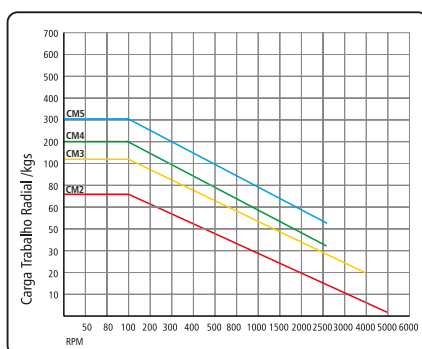

Medidas em: mm

Código	Modelo	Cone Morse	d	d1	D	L1	L
06353	D412B	CM - 2	18	17,780	40	28.5	141
06354	D413B	CM - 3	22	23.925	45	36.5	168
06355	D414B	CM - 4	22	31.267	45	36.5	190
06356	D415B	CM - 5	40	44.399	78	62	267.5

## PINÇA PARA PINO - COM ROSCA INTERNA (MAS 403) - BT (DIN 6499)

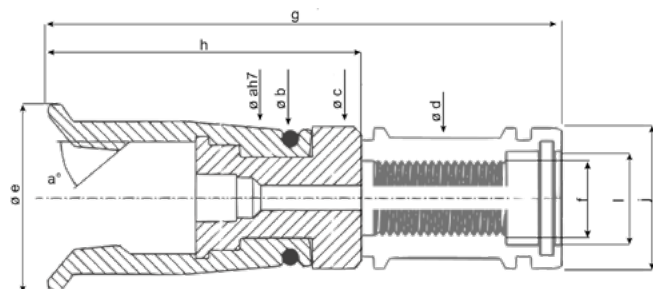

Código	Modelo	a°	ah7	b	c	d	e	f	g	h	i	j
06158	BT40x45°	45°	28	26.4	28.5	-	35	M14x1.5P	86	50	5.5	26
06159	BT50x45°	45°	43	40.4	43.5	28	54	M16x1.5P	106	56	20	40

## PINÇA PARA PINO - COM ROSCA EXTERNA (MAS 403) - BT (DIN 6499)

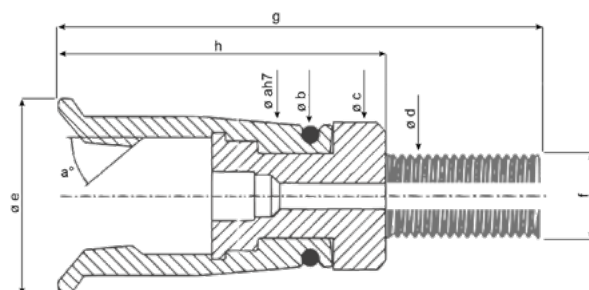

Código	Modelo	a°	ah7	b	c	d	e	f	g	h	i	j
06546	BT40x45°	45°	28	26.4	28.5	16	35	M16x1.5P	86	50	-	-
06547	BT50x45°	45°	43	40.4	43.5	22	54	M22x1.5P	106	65	-	-

## TORNO DE BANCADA

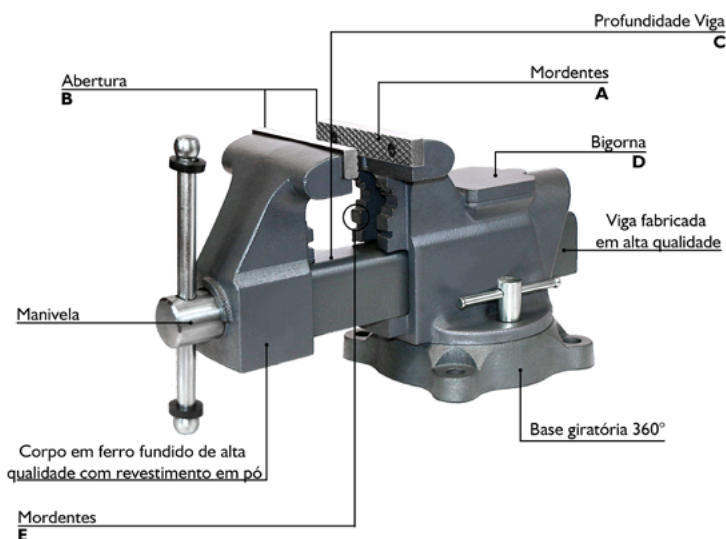

Código	Modelo	A	B	C	D	E	Peso (Kg)
06362	03050-D	125	140	95	78x78	10-75.5	16
06363	03060-D	150	178	107	90x100	17-88.5	24
06364	03080-D	200	200	115	95x100	17-88.5	29.5



**CASTANHA MOLE**  
KITAGAWA

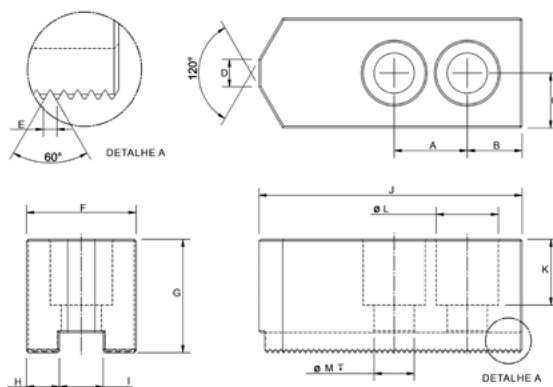
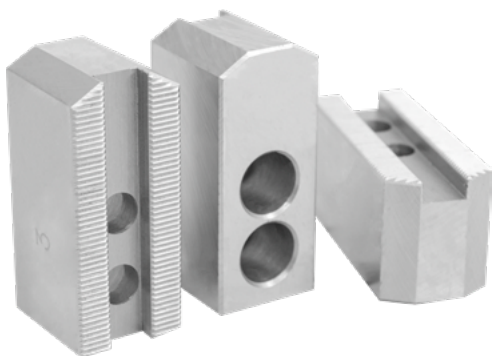

Código	Modelo	A	B	C	D	E	F	G	H	I	J	K	Ø L	Ø M
06346	SJK-12	30	39	25	23	1.5	50	50	14.5	21	130	30	25	17

**CASTANHA MOLE**  
AUTOBLOCK

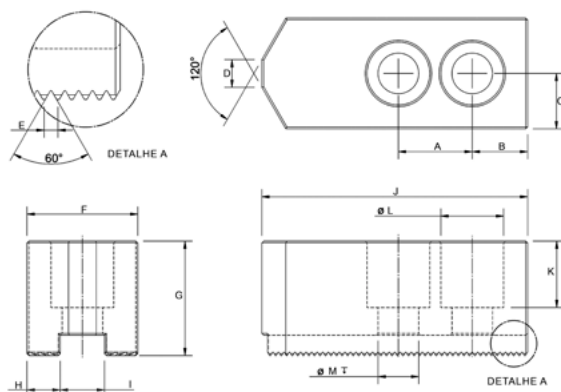
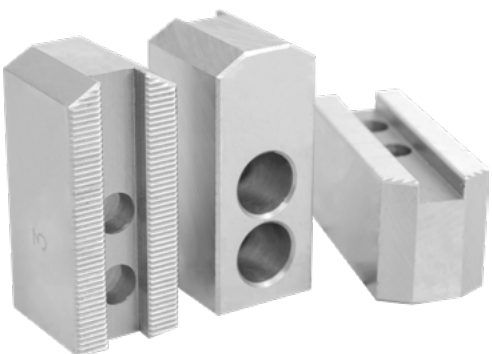

Código	Modelo	A	B	C	D	E	F	G	H	I	J	K	Ø L	Ø M
06347	SJA-6	16	16	15	16	1.5	30	35	8	14	70	25	17	11
06348	SJA-8	23	20	17.5	20	1.5	35	40	9	17	90	30	20	13
06349	SJA-10	30	20	22.5	25	1.5	45	45	12	21	110	33	25	17

**GUIA PARA CASTANHA**  
KITAGAWA

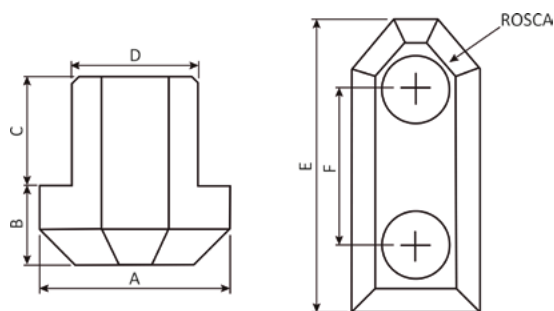

Código	Modelo	A	B	C	D	E	F	Rosca
00791	KIT-6	17.5	7.5	11	12	36.5	20	M10
00792	KIT-8	20	8.5	12	14	46.5	25	M12
00781	KIT-10	22.5	8.5	13	16	51	30	M12

**CASTANHA DURA**  
KITAGAWA

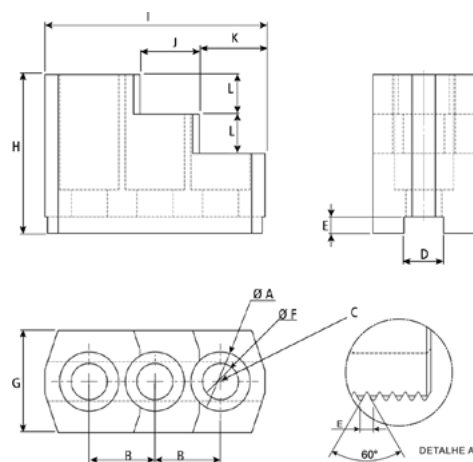

Código	Modelo	A Ø	B	C	D	E	F Ø	G	H	I	J	K	L
06616	HJK-6	-	20	M10x1.5P	12	5	-	31	48.2	67	18	20	12
06617	HJK-8	-	25	M12x1.75P	14	5	-	35	51	87	18	30	12
06618	HJK-10	-	30	M12x1.75P	16	5	-	40	54	101	18	46	13

**CASTANHA DURA**  
AUTOBLOCK

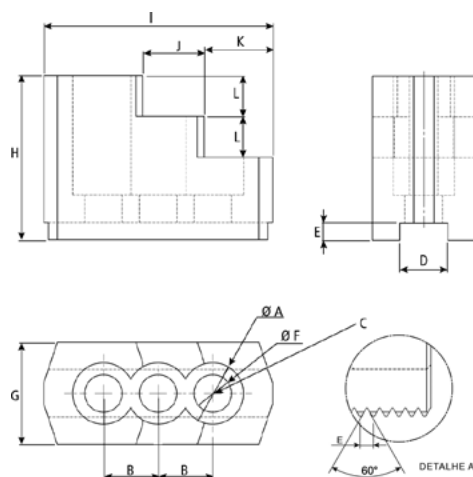

Código	Modelo	A Ø	B	C	D	E	F Ø	G	H	I	J	K	L
06619	HJA-6	18	16	M10x1.5P	14	5	11	30	48.2	67	18	20	12
06620	HJA-8	20	23	M12x1.75P	17	5	13	35	51	87	18	30	12
06621	HJA-10	-	30	M12x1.75P	21	6	-	45	54	101	18	46	13

**GUIAS PARA CASTANHAS**  
AUTOBLOCK

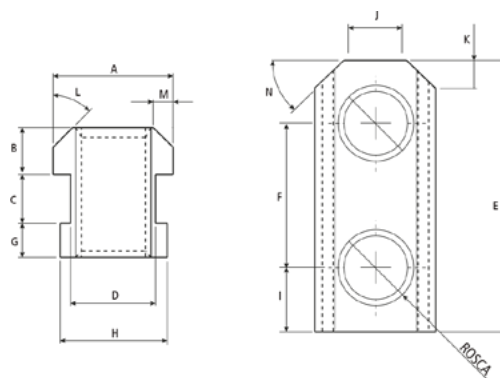

Código	Modelo	A	B	C	D	E	F	G	H	I	J	K	L	M	N	Rosca
06622	AUT-6	17	6.5	7	11	32	16.5	5	14	8	8	4.5	45°	3	45°	M10X1.5
06623	AUT-8	19	7.5	7.6	13	43	23	5.4	17	10	12	4.5	45°	3	45°	M12X1.75
06624	AUT-10	25	10	10	17	56	30	6.5	21	13	14	5	30°	3.5	45°	M16X2.0

## MANDRIL APERTO RÁPIDO INTEGRADO (MAS 403 BT)

- Mandril com auto torque de aperto, proporcionando maior rigidez e força de aperto.
- Estrutura interna com engrenagens.
- Castanhas em aço forjado, garantindo maior resistência e durabilidade.

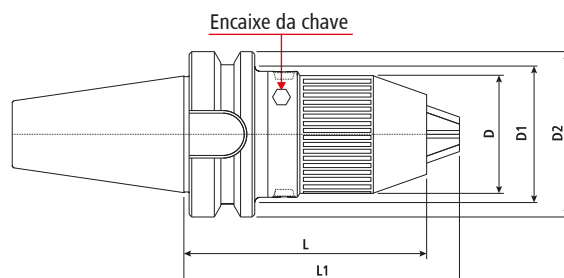

\*Acompanha chave hex. 4.0x100mm

T.I.R.  $\geq 0.03m/2.5xD$

Código	Cone	Modelo	Capacidade	Torque	D	D1	D2	L	L1	Marca
02858	BT40	BT40 NCDC113	1 a 13mm	50Nm	46	50	63	67.6	90	<b>HQT</b>

## JOGO DE PINÇAS HIDRÁULICAS COM CONE (MAS 403 BT)



### Composição:

- Maleta de alumínio
- 6 Pinças hidráulicas vedadas
- 1 Porta pinça hidráulico BT40 - HC20
- 1 Chave hexagonal 5.0x100mm

Código	Cone	Modelo	Capacidade do Mandril	Quantidade de Pinças	Diâmetro das Pinças
05981	BT40	BT40 HC20	3 a 20mm	6	6, 8, 10, 12, 14, 16

## SUPORTE PARA TROCA DE FERRAMENTAS (MAS 403 BT)



Código	Modelo	Cone	Dimensões (mm)
05642	HSK	HSK-63	127.8 x 127.8 x 57.5



**R. Jacob Cemin, 68 - Nossa Sra. de Fátima,  
Caxias do Sul - RS, 95041-230  
Fone: (54) 3021-4119  
E-mail: [vendas@btfixo.com.br](mailto:vendas@btfixo.com.br)  
[www.btfixo.com.br](http://www.btfixo.com.br)**